

LCG50 User's Guide

MEMS Low Cost Gyro

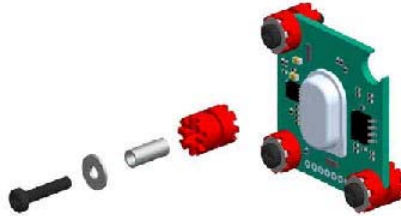

**Model LCG50
Low Cost Gyro
With Temp Sensor**

**Sales and Customer Service
Systron Donner Inertial Division**

Phone: (925) 671-6400
Fax: (925) 671-6647
E-Mail: sales@systron.com

Monday through Friday
7:00 am to 4:00 pm PST
Website: www.systron.com

Table of Contents

SAFETY AND HANDLING INFORMATION.....	3
PATENT INFORMATION	3
INSTALLATION	4
A. LCG50 Mounting	4
B. LCG50 Wiring and Assembly	9
C. LCG50 Connections	9
D. Rate Output.....	10
E. Temperature Sensor Output.....	10
OPERATION AND TROUBLESHOOTING.....	12
A. Bias Not In Specification.....	12
B. Output Tone at 280 or 340 Hz.....	13
C. Input Voltage Regulator Circuit.....	13
D. Technical Assistance.....	16
CONTACT INFORMATION	16

Figures and Tables

FIGURE 1A. LCG50 ENVELOPE DRAWING	5
FIGURE 1B. LCG50 ENVELOPE DRAWING	5
TABLE 1. MOUNTING KIT	6
TABLE 2. ALTERNATE MOUNTING HARDWARE	6
FIGURE 2A. LCG50 TAP AND DRILL PATTERN	7
FIGURE 2B. LCG50 TAP AND DRILL PATTERN	7
FIGURE 3. LCG50 EXPLODED ASSEMBLY	8
TABLE 3. SCALE FACTOR	10
TABLE 4. TEMPERATURE OUTPUT	10
FIGURE 4. LCG50 CONNECTION DIAGRAM.....	11
FIGURE 5. LCG50 PIN ASSIGNMENTS.....	11
FIGURE 6. INPUT VOLTAGE REGULATOR CIRCUIT.....	13
TABLE 5A. LCG50-00100-100 AND LCG50-00250-100 SPECIFICATIONS.....	14
TABLE 5B. LCG50-00500-100 SPECIFICATIONS.....	15

SAFETY AND HANDLING INFORMATION

- **DO NOT DROP!** The LCG50 is a precision instrument. Excessive shock can damage the unit, or destroy the sensing element.
- Avoid exposing the LCG50 to electrostatic discharge (ESD). Wear an ESD wrist strap when handling or soldering wires to the LCG50.
- Insure that input power wires are connected to the power supply with the correct polarity, before applying power to the LCG50.

PATENT INFORMATION

The LCG50 is protected by the following patents: U.S. 5,396,144; U.S. 6,262,520; U.S. 6,507,141; U.S. 6,701,785; Japan 2,512,600; Europe 0638783 plus other U.S. and foreign patents pending.

LCG50-00100-100
LCG50-00250-100
LCG50-00500-100

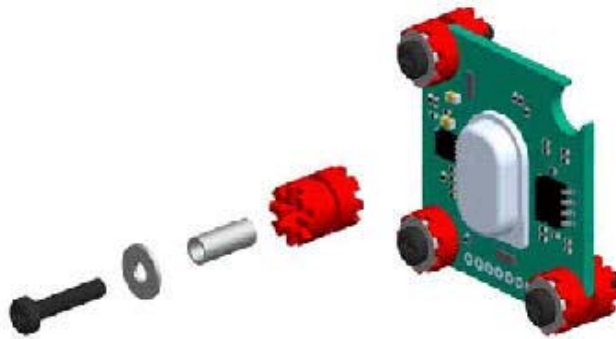

Single Axis Low Cost Gyro

INSTALLATION

A. LCG50 Mounting

1. The LCG50 envelope drawing is shown in Figure 1, for reference purposes.
2. Prepare the mounting surface. It should be sturdy and rigid, and must be flat to within 0.005 inches. If the mounting surface flexes or vibrates, an error will show up in the rate output signal of the LCG50. The LCG50's performance will be degraded.
3. Drill and tap 4 mounting holes in accordance with Figure 2A. Use the supplied kit to mount the LCG50, see Table 1. An exploded assembly is shown in Figure 3.
4. Mount the LCG50 using the mounting hardware listed in Table 1. This hardware is included in the LCG50 mounting kit, P/N 260885, supplied with the LCG50. Refer to Figure 3 for location of mounting holes. Ensure that the washers lay flat with no interference from the side of the case. Note that the sensitive axis orientation is parallel to the mounting surface, as shown in Figure 1A.
5. When mounting the LCG50 to a base plate, tighten screws to between 2.0 and 2.5 in-lbs of torque. Do not over-torque the screws or the LCG50 may be damaged.
6. If through hole mounting is preferred, a hex nut and a longer screw will be required. The required mounting hardware is listed in Table 2, and is not supplied with the LCG50. Drill four through holes, 0.101 Inch Diameter with the pattern shown in Figure 2A.
7. If metric screws are preferred, use a size M2, metric screw of your choice. Drill and tap 4 mounting holes in accordance with Figure 2B. Metric screws are not supplied with the LCG50.
8. Table 1 lists the hardware supplied in the LCG50 Mounting Kit.
9. Table 2 lists the alternate mounting hardware that may be required for alternate mounting methods.

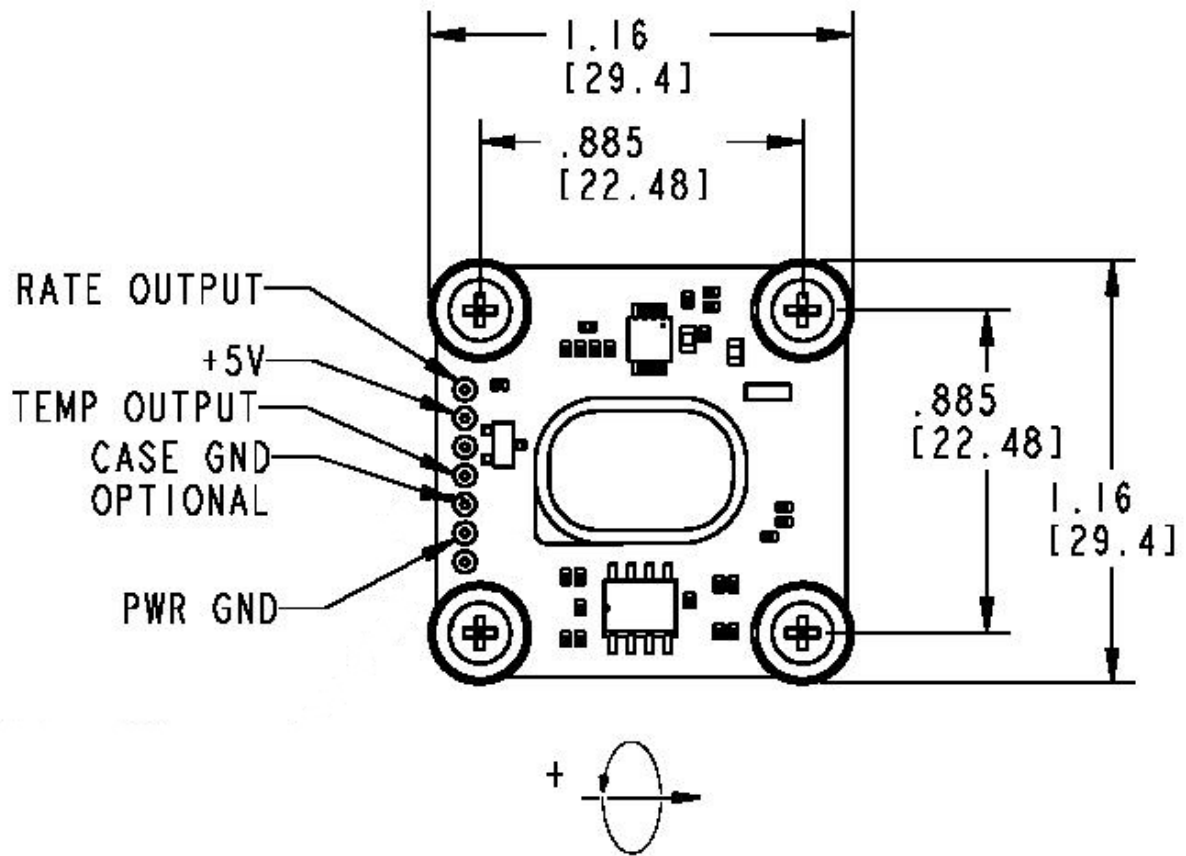

Figure 1A. LCG50 Envelope Drawing

Top View, Dimensions in Inches, Tol: .XXX: $\pm .01$.XX: $\pm .02$

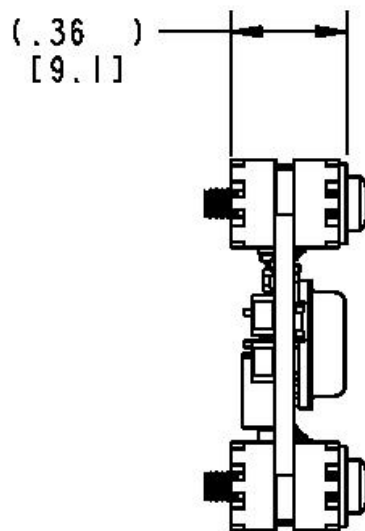

Figure 1B. LCG50 Envelope Drawing

Side View, Dimensions in Inches, Tol: $\pm .02$

Table 1. Mounting Kit
P/N: 260885

Standard	Part Description	Part Number	Qty
US	Isolator, Grommet	P/N: 563771, 7.0 mm OD X 2.4 mm ID X 8.5 mm Long	4
US	Spacer, Isolator	P/N: 564371, .125" OD X .097" ID X .285" Long	4
US	Washer, Flat	Washer, #2, Flat, 3/32" ID X 1/4" OD X .025"	4
US	Screw, Pan Head	2-56, UNC-2A, 7/16 Long, Pan Head Machine Screw	4

Notes:

1. Table 1 lists the hardware supplied in the LCG50 mounting Kit. The LCG50 Mounting Kit was designed to mount the LCG50 to a flat mounting surface with 4 tapped holes.
2. One Mounting Kit is supplied with each LCG50.

Table 2. Alternate Mounting Hardware

Standard	Part Description	Part Number	Qty Req'd
US	Screw, 2-56, 1/2 " Long	2-56, UNC-2A, 1/2 " Long, Pan Head Machine Screw	4
US	Nut, #2, Hex	#2 Hex Nut	4
Metric	Screw, M2 x .4	M2 x .4, 11mm Long, Machine Screw	4
Metric	Washer, M2	M2 Washer	4
Metric	Nut, M2	M2 Nut	4

Notes:

1. Through holes can be used to mount the LCG50, but a longer screw and hex nut would be required. This hardware is listed in Table 2, and is not supplied with the LCG50.
2. Metric screws can be used to mount the LCG50. Size M2 metric screws would be required. This hardware is listed in Table 2, and is not supplied with the LCG50.

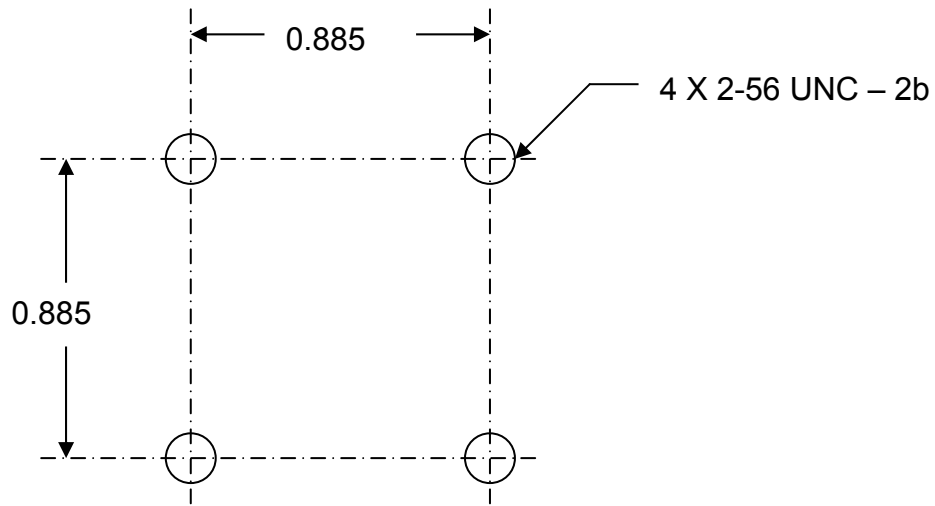

Figure 2A. LCG50 Tap and Drill Pattern
 Dimensions in Inches, Tol: $\pm .005$

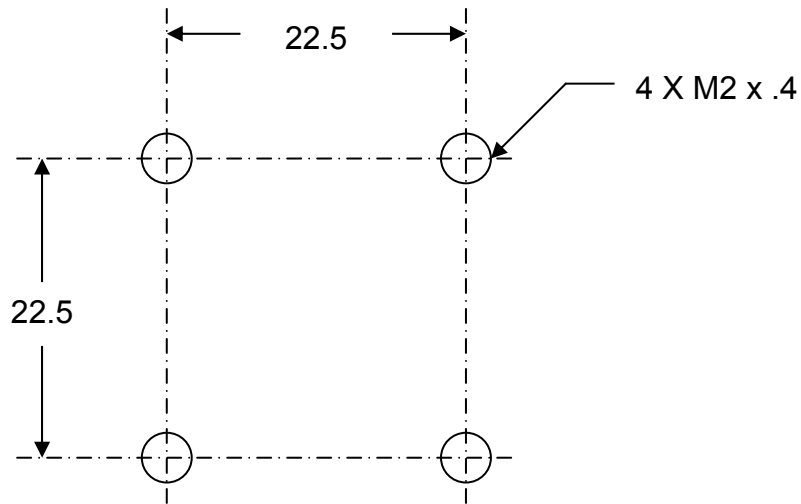

Figure 2B. LCG50 Tap and Drill Pattern
 Dimensions in Millimeters, Tol: $\pm .15$

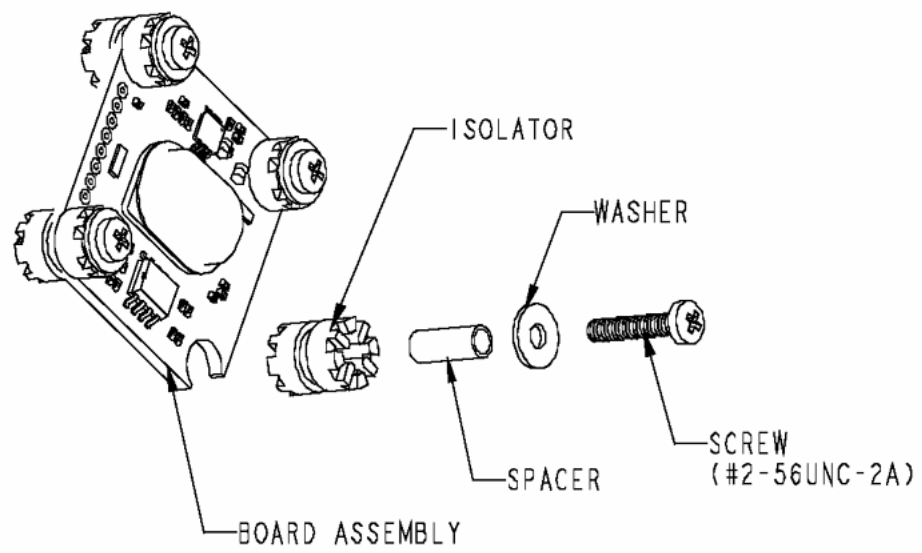

Figure 3. LCG50 Exploded Assembly

B. LCG50 Wiring and Assembly

1. The user can wire the LCG50 directly into the users system or to a connector of choice. The LCG50 gyro has solder pads and through holes that will accommodate 26 AWG wires.
2. Prepare 26 gauge insulated, stranded wires, of the appropriate colors. Allow 2-4" beyond the required length to provide strain relief in the wire routing. Strip 1/4" insulation from the end of each wire. (Proper wire preparation is the key to a good solder bond.)
3. Solder wires to the solder pads in accordance with the pin assignments shown in Figure 4 and Figure 5. Solder wires using a small-tipped 650-700 °F iron for 3-5 seconds.
4. Solder the + 5 V Power wire to E2 or E3. Solder the Power Ground wire to E6 and the Signal Ground wire to E7. Solder the Rate Output wire to E1. Solder the Temp. Sensor Output wire to E4. Solder the Case Ground wire (optional) to E5.
5. When soldering wires, proper care should be exercised. Be careful not to bend the wire near the solder joint to avoid strand separation. Secure the wire bundle with lacing cable about every 3". Do not over-tighten the lacing. Ensure that there is no stress on the wire terminations at either end. There should be a service loop in the wire harness to ensure that the board is allowed to flex on it's rubber isolators.

C. LCG50 Connections

1. Verify power supply polarity before connecting the LCG50. The LCG50's internal electronics are NOT protected against reverse-polarity of power.
2. Connect the LCG50's wires to the system, referring to Figures 4 and 5.
3. Connect the Power Ground (E6) to the common (ground) of the system power supply.
4. The Rate Output signal (E1) and the Temp. Sensor Output (E4) should be referenced to signal ground (E7). Use separate wires for Power Ground (E6) and Signal Ground (E7). This will prevent ground loops and ensure the accuracy of your Rate Output (E1) signal.
5. A Case Ground wire is optional. If used, it should be connected to the system chassis or case.
6. Use short wires to your power supply to minimize impedance in the power lines to the sensor. If power lines longer than three feet (3') are required, it is recommended to use solid tantalum bypass capacitors (10 μ f or more). Place the capacitors between the power lines and ground within 6" of the terminals on the rate sensor.
7. Shielded power input lines and rate output lines are required if operating the LCG50 in the presence of high levels of electromagnetic interference (EMI). Sources of EMI include switching power supplies and radio transmitters.

D. Rate Output

1. The rate output signal is available at the Rate Output on E1. Use Signal Ground (E7) as the common.
2. The Scale Factor depends on the model number and is shown in Table 3, in mV/°/sec.

Table 3. Scale Factor

Scale Factor Table		
Model Number	Scale Factor	Tolerance
LCG50-00100-100	16 mV/°/sec	±15 %
LCG50-00250-100	6.4 mV/°/sec	±15 %
LCG50-00500-100	3.2 mV/°/sec	±15 %

E. Temperature Sensor Output

1. The Temperature Output is available at the Temp. Sensor Output (E4). Use Signal Ground (E7) as the common.
2. The Temp. Sensor Output Voltage can be calculated using the following formula:
$$V_{out} \text{ (mV)} = [6.25 \text{ mV/}^\circ\text{C}] \times [T \text{ (}^\circ\text{C)}] + 424 \text{ mV}$$
3. The Rate Sensor's Temperature in °C can be calculated using the following formula:
$$T \text{ (}^\circ\text{C)} = [V_{out} \text{ (mV)} - 424 \text{ mV}] / [6.25 \text{ mV/}^\circ\text{C}]$$
4. The output voltage for several standard temperatures are shown in Table 4, in mV.

Table 4. Temperature Output

Temperature Output Table	
Temperature (°C)	Voltage (mV)
+85 °C	955 mV
+25 °C	580 mV
0 °C	424 mV
-40 °C	174 mV

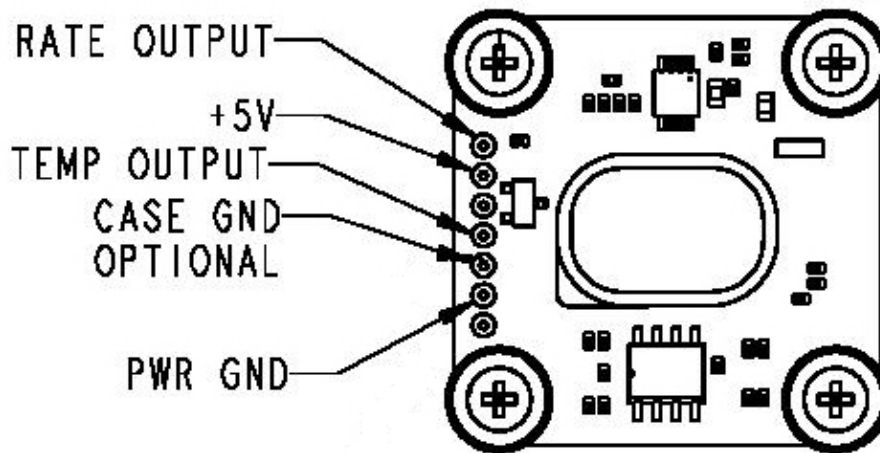
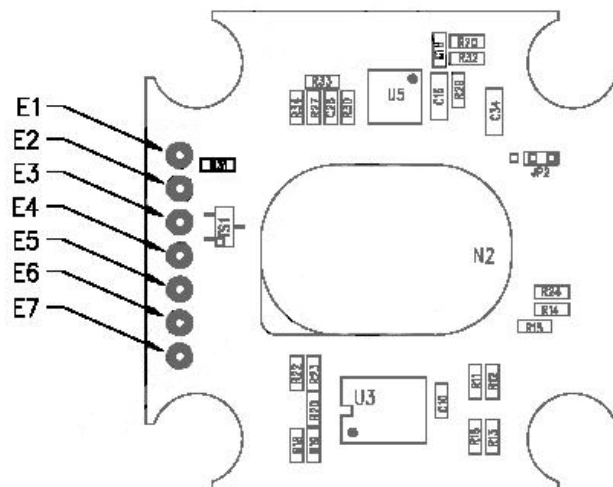

Figure 4. LCG50 Connection Diagram

Pin	Description
E1	Rate Output
E2	+5 Vdc
E3	+5 Vdc
E4	Temp. Sensor Output
E5	Case Ground
E6	Power Ground
E7	Signal Ground



Notes:

1. Power Ground (E6) and Signal Ground (E7) are electrically connected together on the board.
2. When connecting +5 Vdc Input power (E2 or E3), connect the common to Power Ground (E6).
3. When measuring Rate Output (E1), use the Signal Ground (E7) as a common.
4. When measuring the Temp. Sensor Output (E4), use the Signal Ground (E7) as a common.
5. The Case Ground (E5) is electrically connected to Power Ground (E6) through a 0.1 μ f capacitor.
6. The Case Ground (E5, optional) should be electrically connected to your system case or chassis.

Figure 5. LCG50 Pin Assignments

OPERATION AND TROUBLESHOOTING

When installed and connected in accordance with this user's guide, the LCG50 should meet or exceed the specifications listed in Table 3. If the LCG50 does not meet the performance parameters listed in Table 3, here are some suggestions to help resolve the problem. If none of these suggestions solve the problem and the LCG50 is still not working to specification, please prepare a summary of your findings and contact an Applications Engineer at Systron Donner Inertial Division. An Applications Engineer can be contacted by telephone at: 866-BEI-GYRO (866-234-4976), Monday through Friday, 7:00-4:00 PST. An Applications Engineer can be e-mailed at: sales@systron.com.

A. Bias Not In Specification

1. **Structural Vibrations or Mounting Surface Movements:** The LCG50 responds to very small angular movements. When observed rate output signals, appear to be noise or bias, they may be the result of real input motions caused by structural vibrations or mounting surface movements. Retest the LCG50 with all potential vibration sources removed and compare performance with previous results. If this does not solve the problem, try moving the LCG50 to a different mounting location or change the sensitive axis direction.
2. **Bias Shifts:** The power grounds and signal grounds should be connected at only one point. If this is not the case, ground loops may result. Ground loops can cause a bias shift that affects instrument performance. Check the wiring layout for ground loops.
3. **Crosstalk Between GyroChips:** Two or more LCG50 gyros directly connected from the same power supply can possibly crosstalk. This condition will cause bias shifts and increase output noise for each unit. To eliminate power supplies as a cause of crosstalk (see section 4 below), test a single LCG50, after disconnecting all others. If the noise or bias decreases, consider electrical isolation using a voltage regulator as shown in Figure 6 for each individual LCG50. The voltage regulator helps avoid crosstalk between gyros.
4. **Switching Power Supplies:** Switching power supplies have an internal square wave oscillator that generates a 25 KHz signal. On some switching power supplies, this signal can radiate from the power supply and interfere with the operation of the LCG50. This interference may cause a bias shift or an increase in noise in the output of the LCG50. Linear power supplies use a large transformer instead of a square wave oscillator and do not generate this signal. To eliminate this problem, power one LCG50 from a quality bench linear power supply, such as a Lambda Model LQD 422. If the bias shift and/or output noise decreases, use a voltage regulator circuit as shown in Figure 6, to isolate the LCG50 from the switching power supply.

B. Output Tone at 280 or 340 Hz

Under certain conditions of shock and/or vibration, the LCG50 can emit a narrow-bandwidth tone in the region of 280 Hz (± 20 Hz) or 340 Hz (± 20 Hz). This tone is usually not observable in output signals, because the sensor has a bandwidth of 50 Hz with a signal rolloff of -12 dB per octave. If the tone becomes significant in your application, an appropriate filter may be used.

C. Input Voltage Regulator Circuit

To realize the performance parameters specified in Table 3, for the LCG50 Rate Sensor, the input voltage must be well regulated and relatively noise free in certain frequency bands.

When the input voltage source for the LCG50 is unregulated or a switching power supply, it is recommended to install a input voltage regulator in close proximity (within 3 inches) to the LCG50. The input voltage regulator will also reduce crosstalk between multiple rate sensors in a multi-axis package. The suggested Input Voltage Regulator Circuit schematic shown in Figure 6 will regulate the input voltage to the LCG50.

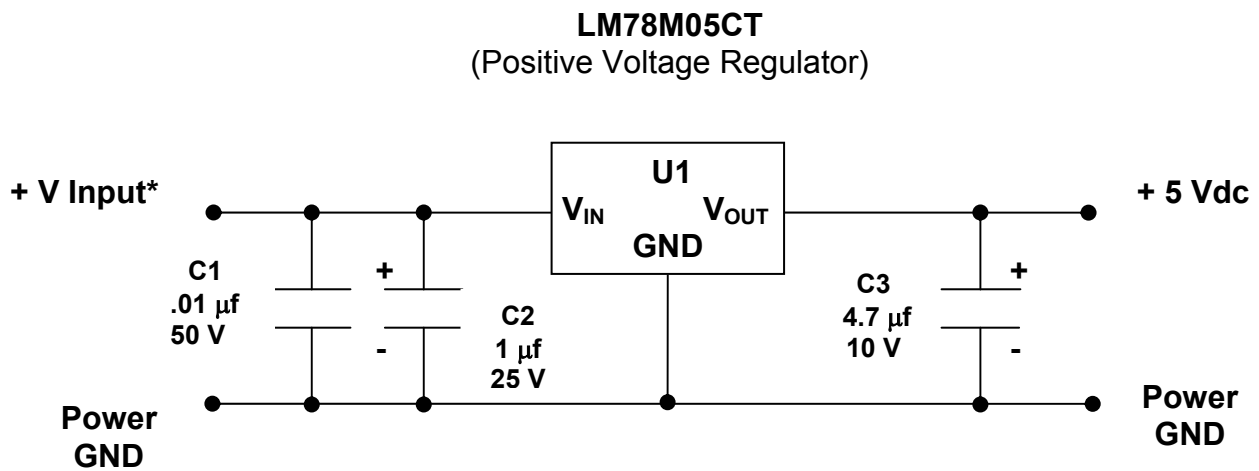

* Voltage Input Range: +7.5 Vdc to +12 Vdc

Figure 6. Input Voltage Regulator Circuit

Table 5A. LCG50-00100-100 and LCG50-00250-100 Specifications

PARAMETER	SUMMARY SPECIFICATIONS	
	LCG50-00100-100	LCG50-00250-100
Part Number	LCG50-00100-100	LCG50-00250-100
Power Requirements		
Input Voltage (Nominal)	+5.0 Vdc	
Input Current	<8 mA @ +5.0 Vdc	
Performance (+5.0 Vdc Input Power)		
Standard Ranges	±100 °/s	±250 °/s
Scale Factor Calibration (at 22°C Typical)	16 mV/°/sec ±15%	6.4 mV/°/sec ±15%
Scale Factor over Temperature	<0.1 %/°C	<0.1 %/°C
Bias Calibration (at 22°C Typical)	+2.5 Vdc ± 0.2 Vdc	+2.5 Vdc ± 0.2 Vdc
Bias Variation over Temperature	8 °/sec	10 °/sec
G Sensitivity (Typical)	<0.05 °/sec./g	
Start-Up Time (Typical)	<2 sec.	
Bandwidth (-3dB)	>50 Hz	
Non-Linearity (Typical) % Full Range	<0.05%	
Output Noise (DC to 100 Hz Typical)	<0.005°/s/√Hz	<0.006°/s/√Hz
Temp Sensor		
Scale Factor (Nominal)	6.25 mV/°C	
Output Voltage at 0°C	+424 mV (Typical)	
Environments		
Operating Temperature	-40°C to +85°C	
Storage Temperature	-55°C to +100°C	
Vibration Operating	5 g _{rms}	
Vibration Survival	10 g _{rms}	
Shock	500g PK ½ sine 2 msec	
Weight	<0.4 oz. [12 grams]	

Table 5B. LCG50-00500-100 Specifications

PARAMETER	SUMMARY SPECIFICATIONS
Part Number	LCG50-00500-100
Power Requirements	
Input Voltage (Nominal)	+5.0 Vdc
Input Current	<8 mA @ +5.0 Vdc
Performance (+5.0 Vdc Input Power)	
Standard Ranges	±500 °/s
Scale Factor Calibration (at 22°C Typical)	3.2 mV/°/sec ±15%
Scale Factor over Temperature	<0.1 %/°C
Bias Calibration (at 22°C Typical)	+2.5 Vdc ± 0.2 Vdc
Bias Variation over Temperature	20 °/sec
G Sensitivity (Typical)	<0.05 °/sec./g
Start-Up Time (Typical)	<2 sec.
Bandwidth (-3dB)	>50 Hz
Non-Linearity (Typical) % Full Range	<0.05%
Output Noise (DC to 100 Hz Typical)	<0.01 °/s/√Hz
Temp Sensor	
Scale Factor (Nominal)	6.25 mV/°C
Output Voltage at 0°C	+424 mV (Typical)
Environments	
Operating Temperature	-40°C to +85°C
Storage Temperature	-55°C to +100°C
Vibration Operating	5 g _{rms}
Vibration Survival	10 g _{rms}
Shock	500g PK ½ sine 2 msec
Weight	<0.4 oz. [12 grams]

D. Technical Assistance

SDID wants you to be satisfied with our products performance. If you have questions or need assistance in operating your LCG50 rate sensor, please call us. An Applications Engineer can be contacted at Systron Donner Inertial Division by telephone at: 866-BEI-GYRO (866-234-4976) or by e-mail at: sales@systron.com.

CONTACT INFORMATION

Systron Donner Inertial Division

2700 Systron Drive · Concord, California 94518-1399

Customer Service: PH: 925-671-6400 · FAX: 925-671-6647

Sales and Technical Support: 866-BEI-GYRO (866-234-4976)

European Business Office: ++44 (0) 1227 776460 FAX: ++44 (0) 1227 363289

E-Mail Address: sales@systron.com · Web Site: www.systron.com

BEI Technologies, Inc. is a diversified technology company providing advanced sensors to the automotive, industrial, aerospace & defense, medical and scientific communities.