

Horizon User's Guide



MEMS Angular Rate Sensor
Model Horizon (HZ1)

Sales and Customer Service
Systron Donner Inertial

RELEASED DOCUMENT
DATE: 08-06-07

Telephone: (925) 979 - 4500
Fax: (925) 979 - 9827
E-mail: sales@systron.com

Monday through Friday
7:00 am to 4:00 pm PST
Website: www.systron.com

SAFETY AND HANDLING INFORMATION

- **DO NOT DROP!** The Horizon is a precision instrument. Excessive shock can adversely affect sensor performance.
- Avoid exposing the Horizon to electrostatic discharge (ESD). Observe proper grounding while handling.
- Insure that power leads are installed properly before applying power to the Horizon.

PATENT INFORMATION

The Horizon is protected by the following patents: U.S. 4,654,663; U.S. 4,524,619; U.S. 4,899,587; U.S. Re. 33,479, plus other U.S. and foreign patents pending.

INSTALLATION

A. Connector Assembly

1. The Mating Connector (AMP MTA-100 OR MOLEX 2695) packaged with the Horizon comes unassembled so that you can customize the wire lengths to your particular installation.
2. Cut 26 gauge insulated wire (stranded). Allow 2-4" beyond what you think you'll need to provide strain relief in your wire routing. Strip 1/4" insulation from the end of each wire. Pre-tin, clean and trim off the excess. Proper wire preparation is the key to a good solder bond; a clean soldering iron tip will insure an uncontaminated solder joint.
3. Install each wire into the connector termination and crimp wire into place with needlenose pliers. Make sure there is a good mechanical connection. Solder wires using a small-tipped 650-700° F iron for 3-5 seconds.
4. Check **Table 1** for correct pin assignment. Insert each pin into the correct hole of the mating connector housing. Secure the wire bundle with lacing or zip cable about every 3". Do not over-tighten the lacing. Insure that there is no stress on the wire terminations at either end.

Table 1. Connector Pin Wiring Assignments

Connector Pin	HZ1-90-100A	HZ1-100-100	HZ1-200-100
1	+ 8 to + 15 VDC Input	+ 8 to + 15 VDC Input	+ 8 to + 15 VDC Input
2	Rate Output	Rate Output	Rate Output
3	Ref. Voltage +2.5 Vdc	Ref. Voltage +2.5 Vdc	Ref. Voltage +2.5 Vdc
4	No connection, leave open	No connection, leave open	No connection, leave open
5	Power & Signal Ground	Power & Signal Ground	Power & Signal Ground

Figure 1. Connection Diagram for Model Horizon

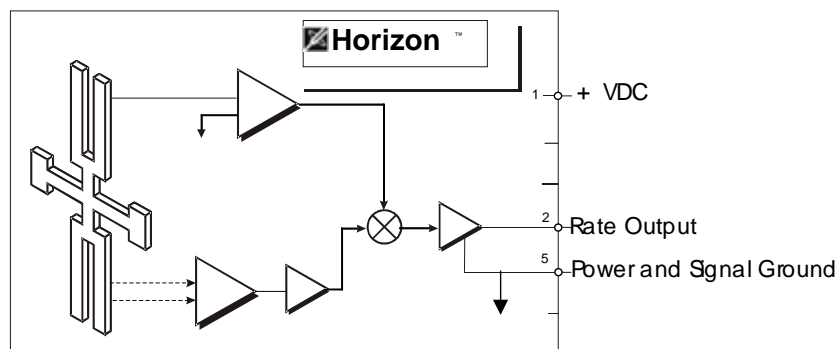

A. Mounting

1. Prepare the mounting surface. It should be sturdy and rigid, and must be flat within 0.005 inches. If the mounting surface flexes or vibrates, the Horizon will respond to the movement as an input.
2. Mount the Horizon using two small flat washers and 4-40 UNC screws or equivalent. The maximum mounting screw penetration is 0.20". Refer to **Figure 2** for location of tapped mounting holes. *Note that the sensitive axis orientation is parallel to the mounting surface.* Refer to SDI Horizon outline drawing number 962987.
3. Tighten screws to 5 in-lbs of torque for mounting. Over-torquing may damage the case or strip the threads.

B. Connection

1. *Verify power supply polarity before connecting the Horizon. The instrument's internal electronics are NOT protected against reverse-polarity power.*
2. Connect the wires, referring to **Figure 1**, **Figure 2** and **Table 1**. Note the different pin designations associated with each model.
3. Connect the power ground to the common (ground) of the power supply. Signal ground is common to power ground in the design. There is an internal jumper between signal ground and power ground. Power Ground is also tied internally to the case (optional on the 100C).
4. Minimize impedance of the supply power lines at the sensor. If you are using cables longer than three feet (3'), it is recommended to use solid tantalum bypass capacitor (10 μ f or more). Place the capacitors between the power line and ground within 6" of the terminals on the rate sensor.
5. Shield power input lines if you are operating the Horizon in the presence of high levels of electromagnetic interference (EMI). Sources of EMI include switching power supplies and radio transmitters.
6. Insert a presampling filter when using an analog-to-digital (A-D) converter with the Horizon. Set the bandwidth of the presampling filter at 1/4 to 1/3 of the sampling frequency.

OPERATION AND TROUBLESHOOTING

When properly installed and connected, the Horizon should meet or exceed the specifications listed on **Table 2**. If you do not achieve this level of performance when operating your Horizon, one of the following suggestions should resolve the problem. If not, please prepare a summary of your findings and call an Applications Engineer at Systron Donner Inertial: 866-BEI-GYRO (866-234-4976), Monday through Friday, 7:00-4:00 PST.

A. Bias Not In Specification

1. *Structural Vibrations or Mounting Surface Movements.* The Horizon responds to very small angular rates. Observed voltage outputs, thought to be noise or bias, may result from real input motions caused by structural vibrations or mounting surface movements. Test the Horizon with all potential vibration sources shut off and compare performance with previous results. Alternatively, move the Horizon to a different mounting location or change the sensitive axis direction.
2. *Bias Shifts Caused by Ground Loops.* Ground loops may cause a bias shift that affects instrument performance. Check the wiring layout for ground loops.

3. *Crosstalk Between Horizon Units.* Two or more Horizon units directly connected from the same power supply can possibly crosstalk, increasing bias or noise generation for each unit. First, eliminate power supplies as a cause of crosstalk (see #4 below). Then, test a single Horizon after disconnecting all others. If the noise or bias decreases, consider electrical isolation using an R-C Pi filter network on each of the power lines to the individual Horizon instruments.
4. *Switching Power Supplies.* Some switching power supplies may cause a bias or noise increase in the output of the Horizon. Run one Horizon from a quality bench linear power supply, such as a Lambda Model LQD 422, or from a set of batteries, to see if the switching power supplies are the problem. If the bias/noise decreases, put a 100 uf capacitor and a 0.1µf ceramic bypass capacitor between the power supply lines and ground within 6" of the Horizon before reconnecting the switching power supplies.

C. Output Tone at 340 Hz

Under certain conditions of shock and/or vibration, the Horizon can emit a narrow-bandwidth tone in the region of 340 Hz (± 20 Hz). This tone is usually not observable in output signals, because the sensor has an approximate corner frequency of 18 Hz or 50 Hz (depending on model) with a signal rolloff of -12 dB per octave. If the tone becomes significant in your application, an appropriate filter may be used.

D. Technical Assistance

We want you to be thoroughly satisfied with our product. If you have questions or need assistance in operating your Horizon, please call us. You can reach an Applications Engineer at Systron Donner Inertial by calling 866-BEI-GYRO (866-234-4976).

FIGURE 2 *Horizon Outline Details*

Outline dimensions are in inches.
Dimensions in brackets are in [millimeters].

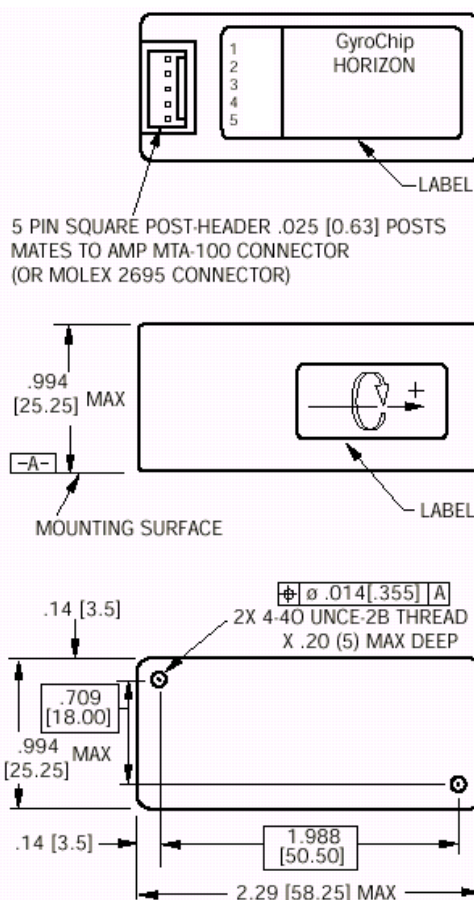

Table 2. Horizon Specifications

Power Requirements	HZ1-90-100A	HZ1-100-100	HZ1-200-100
Input Supply Voltage	+8 to +15 VDC	+8 to +15 VDC	+8 to +15 VDC
Input Supply Current (max)	< 20 mA	< 20 mA	< 20 mA
Performance			
Range	±90°/sec	±100°/sec	±200°/sec
Full Scale Output	+0.5 Vdc (-FS) to +4.5 Vdc (+FS)		
Scale Factor (±2%)	22.2 mV/°/sec	20.0 mV/°/sec	10.0 mV/°/sec
S.F. Over Operating Temperature (Deviation from 22 °C)	< 0.08%/°C	< 0.08%/°C	< 0.08%/°C
Bias (Initial offset at 22 °C)	+2.5 ±0.045VDC	+2.5 ±0.045VDC	+2.5 ±0.045VDC
Bias Stability			
Long-term (one year)	< 1.0°/sec	< 1.0°/sec	< 1.0°/sec
Over Operating Environments (Deviation from 22 °C)	< 4.5°/sec	< 4.5°/sec	< 4.5°/sec
g Sensitivity (all axes)	< 0.06°/sec/g	< 0.06°/sec/g	< 0.06°/sec/g
Linearity Error	< 0.05% of F.R	< 0.05% of F.R	< 0.05% of F.R
Output Noise (to 100 Hz)	< 0.025°/sec/√Hz	< 0.025°/sec/√Hz	< 0.025°/sec/√Hz
Bandwidth (-90° Phase shift)	> 18 Hz	> 60 Hz	> 60 Hz
Resolution and Threshold	< 0.004°/sec	< 0.004°/sec	< 0.004°/sec
Start-up time	< 1.0 sec	< 1.0 sec	< 1.0 sec
Environments			
Operating Temperature	-40° C to +71° C	-40° C to +71° C	-40° C to +71° C
Storage Temperature	-55° C to +100° C		
Vibration Operating	2 g _{rms} 20 to 2K Hz random		
Vibration Survival	10 g _{rms} 20 to 2K Hz random, 5 min/axis		
Shock	200 g pk, 2 ms, ½ sine		
Weight	< 60 grams		

CONTACT INFORMATION

Systron Donner Inertial

355 Lennon Lane · Walnut Creek, California 94598

Customer Service: PH: 925-979-4500 · FAX: 925-979-9827
 Sales and Technical Support: 866-BEI-GYRO (866-234-4976)
 E-Mail: sales@systron.com · Web Site: www.systron.com

European Business Office: ++44 (0) 1227 776460 · FAX: ++44 (0) 1227 363289
 E-Mail: bei.tech@ukonline.co.uk