

MMQ50-200-400 User's Guide



**Sales and Customer Service
Systron Donner Inertial**

Phone: +1 925.979.4500 Fax: +1 925.349.1366

E-Mail: sales@systron.com

www.systron.com

Table of Contents

1	Purpose	5
2	Interface Definitions	5
2.1	Interface Connector	5
2.1.1	Power	5
2.1.2	Digital Output	5
2.1.3	Serial Output	5
2.2	Electrical Characteristics.....	5
2.3	Connector Characteristics	5
2.4	Power Connections	5
2.4.1	+12.0 VDC.....	5
2.4.2	-12.0 VDC.....	5
2.4.3	Ground	5
3	Data Descriptions	6
3.1	Digital Output Descriptions	6
3.1.1	Power Good	6
3.1.2	Data Good	6
3.1.3	System Fault	6
3.2	Serial Output Descriptions	6
3.2.1	Bit Message	6
3.2.1.1	Header Word	6
3.2.1.2	Checksum	6
3.2.1.3	Data Word Count	6
3.2.1.4	Data Word Meanings	6
3.2.1.5	BIT Status Word 1	7
3.2.1.6	BIT Status Word 2	7
3.2.2	Initial Bit Message	7
3.2.2.1	Header Word	7
3.2.2.2	Checksum	8
3.2.2.3	Data Word Count	8
3.2.2.4	Data Word Meanings	8
3.2.3	Normal Data Message.....	9
3.2.3.1	Header Word	9
3.2.3.2	Checksum	9
3.2.3.3	Data Word Count	9
3.2.3.4	Data Word Meanings	9
4	Examples	10
4.1	Serial Data Messages	10
4.1.1	Normal Data Message.....	10
4.1.2	Initial Bit Message	10
5	Appendices	10
5.1	MMQ50-200-400 Prime interface (J1)	14
5.2	Specifications.....	15
5.3	Specification Definitions and Measurement Techniques.....	16
5.3.1	Specifications vs. Acceptance Test Limits	16
5.3.2	Measurement Techniques	17
5.3.3	Definitions of Specifications	17
5.3.3.1	Turn-on to turn-on Stability (Specified)	17

5.3.3.2 In-run stability (Specified)	17
5.3.3.3 Gyro and Accelerometer Bias (Specified)	17
5.3.3.4 Noise Floor (Specified)	18
5.3.3.5 White Noise (Angle Random Walk) (Specified)	18
5.3.3.6 RMS noise (Not Specified)	18
5.3.3.7 Scale Factor Error (Specified)	18
5.3.3.8 Alignment (Specified)	18
5.3.3.9 Orthogonality (Not Specified)	19
5.3.3.10 Vibration Rectification (Specified)	19
5.3.3.11 Gyro g-sensitivity (Specified)	19
5.3.3.12 Cross-axis sensitivity (Not Specified)	19
5.3.3.13 Bandwidth (Specified)	19

Tables Index

Table 1: Digital Output Truth Table	6
Table 2: Bit Status Word 1	7
Table 3: Bit Status Word 2	7
Table 4: Initial Bit Message	8
Table 5: BIT Message scale factors	9
Table 6: Normal Data Message	10

Purpose

This document provides the MMQ specification, and defines the interface between the MMQ series of Miniature MEMS Quartz IMU's ("MMQ") and the host system. It contains all information needed to connect to and communicate with the MMQ.

Interface Definitions

There is a single 34-pin connector to this system. All power and signals are routed through this connector.

1.1 Interface Connector

1.1.1 Power

This system requires conditioned power from the host. Required power is +/- 12 VDC and a common ground. Acceptable voltages are +/-11.0 to +/-13.0VDC, with 50mV or less of noise/ripple. Risetimes should not exceed 10mS. Steady state current draw is approximately 280mA (+12V) and -80 mA (-12V).

1.1.2 Digital Output

There are three digital output connections. These pins indicate the status of the system. The digital outputs support limited current draw. Total draw for the outputs should not exceed 5 mA total. Note that there should not be more than 2 outputs active at any time. Output voltages conform to LVTTTL standards (0–3.3V)

1.1.3 Serial Output

Serial output is valid in all states. Output messages are per this ICD Format. Valid serial data values range from 0x8012 (-32750) to 0x7FEE (32750). Values outside of this range are used as header words and fault conditions.

1.2 Electrical Characteristics

Pins intended for external users are buffered 0-3.3VDC logic levels.

Serial Input/Output is according to the RS232 protocol. Serial data rate is 115,200 bits per second (115k baud). See also paragraph 3.2.

1.3 Connector Characteristics

The connector is a 34-pin, dual row SamTec "EHF" series header, with locking/ejection cams, and an orientation cutout. The connector pins are on a 1.25mm pitch square grid.

1.4 Power Connections

1.4.1 +12.0 VDC

Pin 22 of the 34-pin interface connector is the +12.0 VDC connection. Current draw \cong 280mA.

1.4.2 -12.0 VDC

Pin 12 of the 34-pin interface connector is the -12.0 VDC connection. Current draw \cong -80mA.

1.4.3 Ground

Pin 29 of the 34-pin interface connector is the ground connection. Pin 30 is the Chassis

connection, which is internally connected to power ground.

Data Descriptions

1.5 Digital Output Descriptions

1.5.1 Power Good

This pin indicates a 1 when the measured voltage levels at the DSP are sufficient to operate the system.

1.5.2 Data Good

This pin indicates a 1 when the system output is valid, and a zero prior to that time.

1.5.3 System Fault

This pin indicates a 1 when the software has detected a fault in the system, and a zero at all other times.

Pin:	Power Good	Data Good	System Fault
Mode:			
Normal	1	1	0
Fault	D/C	D/C	1

Table 1: Digital Output Truth Table

1.6 Serial Output Descriptions

All serial outputs are a tag word followed immediately by a checksum and then one or more data words.

Serial data is byte wise with one start and one stop bit per byte, no parity.

Serial data output messages are all even word length, a word being considered to be 16 bits.

Each message contains a checksum as word 2. The arithmetic sum of the entire message should be zero in the low 16 bits if received correctly. The intent is that the tag word value is not a valid data word. It may be that the checksum word matches a tag word, however.

Transmission is sent Low-byte, High Byte with Least Significant bit first in each case. A logical one is a low voltage on the RS232 Tx Signal.

1.6.1 Bit Message

1.6.1.1 Header Word

The Bit status message is identified by the value 0x8011 as the tag word.

1.6.1.2 Checksum

The second word is a 2s-complement of the 16-bit sum of the rest of the entire message.

1.6.1.3 Data Word Count

There are two data words in this message

1.6.1.4 Data Word Meanings

Bits are numbered 15 for MSB and 0 for LSB. Two bits are reserved at the beginning of each word to ensure no conflicts with tag words or fault data values. The nominal value of both words in a no-fault

condition is zero (0x0000). All of these bits are 'sticky' and remains set until power is cycled.

1.6.1.5 BIT Status Word 1

Bit Number Start	# Bits	Definition	Meaning if Set
15	1	Reserved	Not Used
14	1	Reserved	Not Used
13	1	Bit Fault Detected	Detected
12	1	Program Checksum Fault	Block Non Zero
11	1	Communications Fault	Failed
10	1	Failed Input Accel X	Accel Fault
9	1	Failed Input Gyro X	Gyro Fault
8	1	Failed Input Accel Y	Accel Fault
7	1	Failed Input Gyro Y	Gyro Fault
6	1	Failed Input Accel Z	Accel Fault
5	1	Failed Input Gyro Z	Gyro Fault
4	1	Clock Failure	Clock Fault
3	1	Temperature Failure	Out of Range Temp on #ID
2	1	Watchdog Fired	Fired during Task #ID
1	1	Low Voltage	Low Voltage on #ID
0	1	Reserved	Not Used

Table 2: Bit Status Word 1

1.6.1.6 BIT Status Word 2

Bit Number Start	# Bits	Definition	Meaning if Set
15	1	Reserved	Not Used
14	1	Reserved	Not Used
13	1	High Voltage	Over Voltage on #ID
12	4	#ID	Temp/Volt/Task Faulted
8	1	Coefficient Checksum Fault	Block Non Zero
7	1	Coefficient Flag	Using Default Coefficients
6	3	Flash Error Block ID	Faulted Block ID
3	4	Reserved	Reserved

Table 3: Bit Status Word 2

1.6.2 Initial Bit Message

The initial bit message will be generated once at system startup prior to the 'Data Good' discrete being raised. This is after initialization, so all transmitted values are valid. It will also be generated once after the 'System Fault' discrete is raised.

1.6.2.1 Header Word

The Initial Bit status message is identified by the value 0x8012 as the tag word.

1.6.2.2 Checksum

The second word is a 2s-complement of the 16 bit sum of the rest of the entire message.

1.6.2.3 Data Word Count

There are twenty eight data words in this message, which includes the two normal bit status flag words.

1.6.2.4 Data Word Meanings

Word #	Meaning	Length	Minimum Decimal (Hex)	Maximum Decimal (Hex)	Offset	Range
1	Raw X Accel	16 bits	-32750 (8012)	32750 (7FEE)	0	+/- ~300m/s ²
2	Raw X Rate	16 bits	-32750 (8012)	32750 (7FEE)	0	+/- 250 °/sec
3	Raw Y Accel	16 bits	-32750 (8012)	32750 (7FEE)	0	+/- ~300m/s ²
4	Raw Y Rate	16 bits	-32750 (8012)	32750 (7FEE)	0	+/- 250 °/sec
5	Raw Z Accel	16 bits	-32750 (8012)	32750 (7FEE)	0	+/- ~300m/s ²
6	Raw Z Rate	16 bits	-32750 (8012)	32750 (7FEE)	0	+/- 250 °/sec
7	X Accel Temp	16 bits	-32750 (8012)	32750 (7FEE)	32768	-98 to 162 C
8	X Rate Temp	16 bits	-32750 (8012)	32750 (7FEE)	32768	-98 to 162 C
9	Y Accel Temp	16 bits	-32750 (8012)	32750 (7FEE)	32768	-98 to 162 C
10	Y Rate Temp	16 bits	-32750 (8012)	32750 (7FEE)	32768	-98 to 162 C
11	Z Accel Temp	16 bits	-32750 (8012)	32750 (7FEE)	32768	-98 to 162 C
12	Z Rate Temp	16 bits	-32750 (8012)	32750 (7FEE)	32768	-98 to 162 C
13	A/D Temp	16 bits	-32750 (8012)	32750 (7FEE)	32768	-98 to 162 C
14	DSP Temp	16 bits	-32750 (8012)	32750 (7FEE)	32768	-98 to 162 C
15	+5 VDC	16 bits	-32750 (8012)	32750 (7FEE)	32768	0 – 6.5 V
16	+3.3 VDC	16 bits	-32750 (8012)	32750 (7FEE)	32768	0 – 5 V
17	+1.9 VDC	16 bits	-32750 (8012)	32750 (7FEE)	32768	0 – 3 V
18	+12 VDC	16 bits	-32750 (8012)	32750 (7FEE)	32768	0 -14 V
19	-12 VDC	16 bits	-32750 (8012)	32750 (7FEE)	32768	-6 to -14V nom
20	1.25V Ref	16 bits	-32750 (8012)	32750 (7FEE)	32768	0 – 2.10 V
21	X Rate Volts	16 bits	-3275 0(8012)	32750 (7FEE)	32768	0-3.3 V
22	X Accel Volts	16 bits	-32750 (8012)	32750 (7FEE)	32768	0-3.3 V
23	Serial Number	16 bits	0	65535		0-65535
24	Software ID	16 bits	0	65535		0-65535
25	Program Date	16 bits	100	36623		Julian day
26	Program Date	16 bits	0	65535		Year (AD)
27	Bit Sts Word1	16 bits	0000	3FFF		Fault Bits
28	Bit Sts Word2	16 bits	0000	3FFF		Fault Bits

Table 4: Initial Bit Message

Scale factor for the Accelerometers is 326.3 counts/m/s² (3200 counts/g). Scale factor for the Rate Sensors is 100 counts/°/sec. Data words 7 thru 22 (temperatures and voltages) can be converted to actual values using the table 5, below. Some software versions use Words 25 and 26 to define the time of calibration, the Product Code and the Model Number.

Measurement	Nom Value	Counts @ nominal value	Scale Factor (=Bit weight)
Temps	0.0 °C	40724	-252 per °C
+5V	+5.0V	21,845	10,923 per V
+3.3V	+3.3V	15,292	14,564 per V
+1.9V	+1.9V	6,554	21,846 per V
+12V (Vin+)	+12.0V	1040	12482 per V
-12V (Vin-)	-12.0V		Vmeas; Calculated from internal +5V (line 1 of this table) and Vin- Vin-= (5.107x(Vmeas) – 4.107x(5Vmeas))
+1.25V Ref	+1.25V	-5,461	21,846 per V
X-Rate (Volts)	0.0	-5,461	90 counts per deg/sec, nominal (This function not implemented in all versions)
X-Accel (Volts)	0.0	-5,461	600 counts per g, nominal (This function not implemented in all versions)

Table 5: BIT Message scale factors

1.6.3 Normal Data Message

This is the message transmitted in the nominal operational state. This message is transmitted at a nominal rate of 450 Hz.

Note that the accelerations and rates are in units of m/s² and degrees/second. For delta-velocity and delta-theta, divide the acceleration and rate by the output rate.

1.6.3.1 Header Word

The Header Word for a Normal Data Message is 0x7FFF

1.6.3.2 Checksum

The second word is a 2s-complement of the 16 bit sum of the rest of the entire message.

1.6.3.3 Data Word Count

Data Word Count for a Normal Data Message is nine.

1.6.3.4 Data Word Meanings

Word #	Meaning	Length	Minimum Decimal (Hex)	Maximum Decimal (Hex)	Range
1	Compensated X Accel	16 bits	-32750(8012)	32750 (7FEE)	+/- 100 m/s ² (Note 1)
2	Compensated X Rate	16 bits	-32750(8012)	32750 (7FEE)	+/- 200 °/sec
3	Compensated Y Accel	16 bits	-32750(8012)	32750 (7FEE)	+/- 100 m/s ² (Note 1)
4	Compensated Y Rate	16 bits	-32750(8012)	32750 (7FEE)	+/- 200 °/sec
5	Compensated Z Accel	16 bits	-32750(8012)	32750 (7FEE)	+/- 100 m/s ² (Note 1)
6	Compensated Z Rate	16 bits	-32750(8012)	32750 (7FEE)	+/- 200 °/sec
7	Reserved	16 bits	0	0	N/A
8	Reserved	16 bits	0	0	N/A
9	Serialized for Factory use	16 bits	0	0	N/A

Table 6: Normal Data Message

Note1: Maximum steady-state output.

Scale factor Scale factor for the Accelerometers is 3200 counts/g (326.3 counts/m/s²). Scale factor for the Rate Sensors is 100 counts/°/sec.

Examples

1.7 Serial Data Messages

1.7.1 Normal Data Message

0x7FFF, 0x71DF, 0x0010, 0xFFFF0, 0x0022, 0xFFA0, 0x0050, 0x0CCB, 0x0, 0x0, 0x0145

1.7.2 Initial Bit Message

0x8012, 0xA14C, 0x0100, 0xFFFF0, 0x0120, 0xFFA0, 0x3050, 0xFEED, 0x7720, 0x7721, 0x7722, 0x7723, 0x7724, 0x7725, 0x7726, 0x7727, 0xD6D8, 0xC350, 0x9C40, 0xAFCB, 0x5208, 0x6978, 0x0100, 0x0200

Appendices

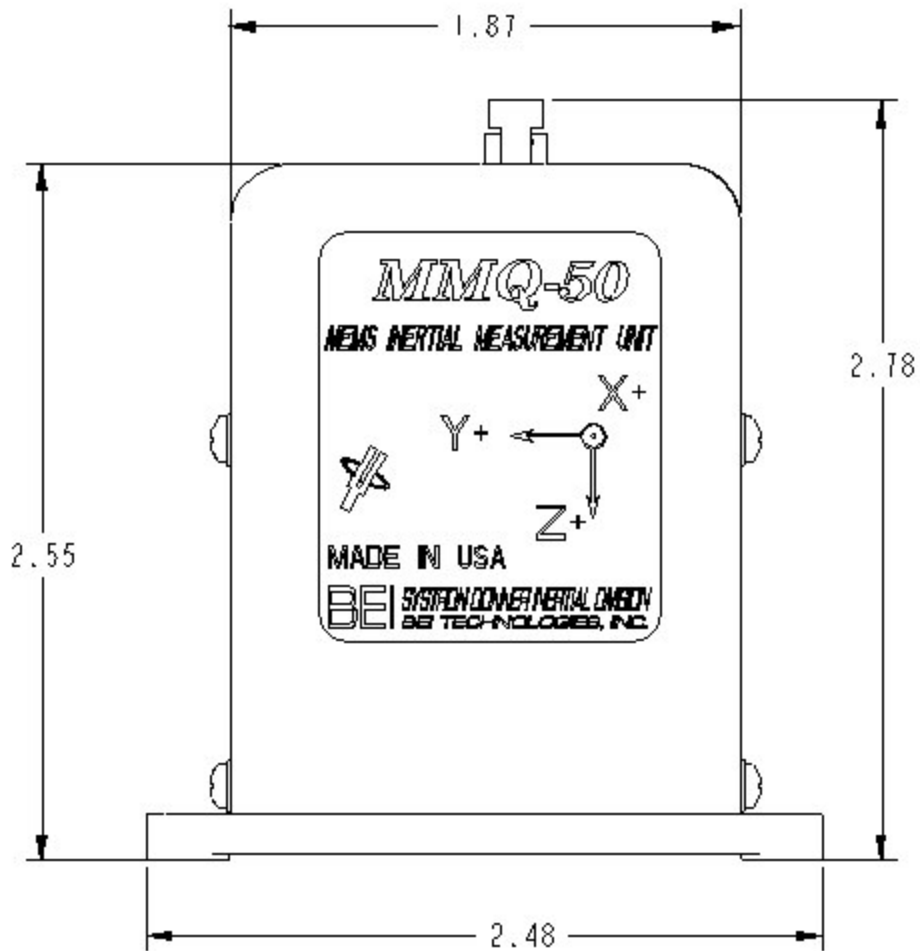

Page 1 of MMQ50 Outline Drawing Interface

4X \varnothing .150
FOR #6 SOCKET SCREW

\varnothing .008 A B C

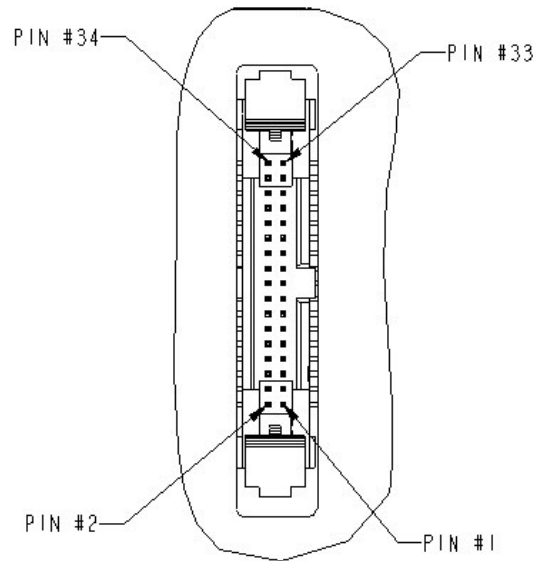
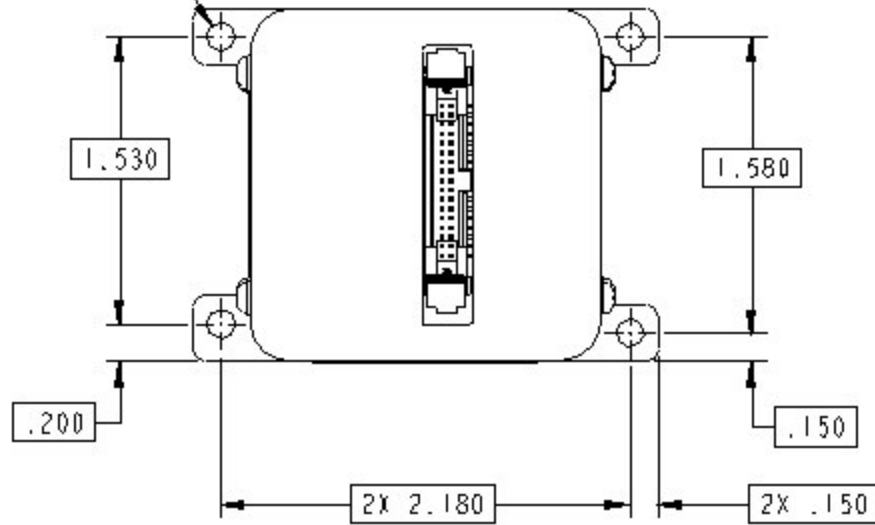

Page 2 of MMQ50 Outline Drawing Interface

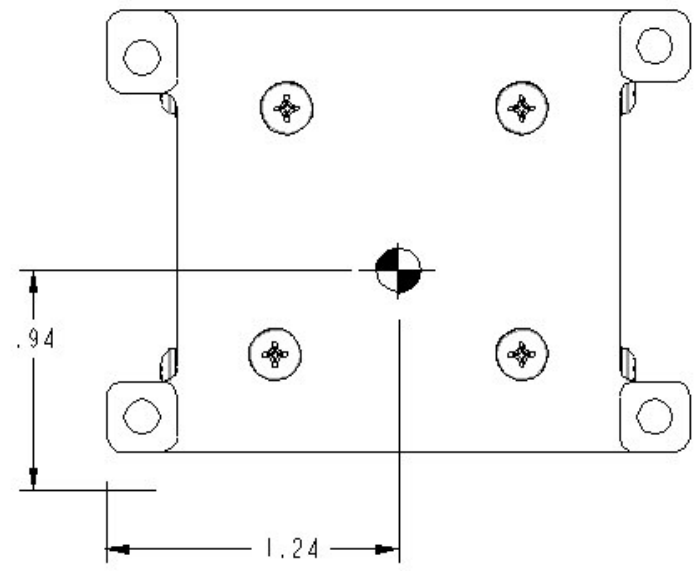
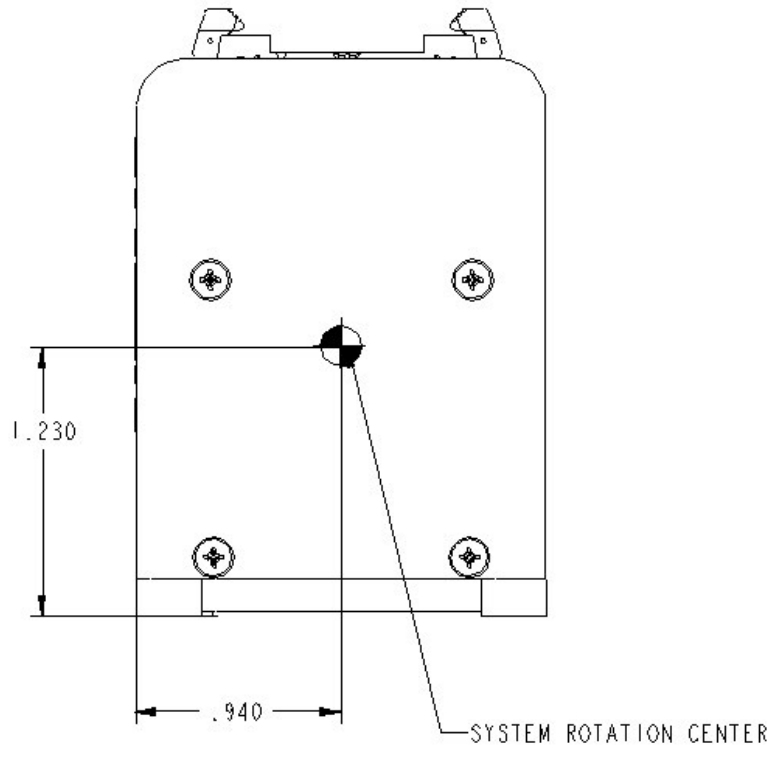

Page 3 of MMQ50 Outline Drawing Interface

Pin #	Pin Name		Comment
1	NC	OUT	Factory use only- do not connect
2	NC	IN	Factory use only- do not connect
3	NC	NC	
4	NC	NC	
5	RS232TX_1	OUT	Serial data to Host Vehicle
6	RS232RX_1	IN	Serial data from Host Vehicle
7	NC	NC	
8	NC	NC	
9	NC	IN	Factory use only- do not connect
10	NC	IN	Factory use only- do not connect
11	NC	IN	Factory use only- do not connect
12	-VIN	IN	Negative power input
13	NC	OUT	Factory use only- do not connect
14	NC	IN	Factory use only- do not connect
15	NC	I/O	Factory use only- do not connect
16	NC	IN	Factory use only- do not connect
17	NC	I/O	Factory use only- do not connect
18	NC	IN	Factory use only- do not connect
19	NC	NC	
20	NC	IN	Factory use only- do not connect
21	NC	NC	
22	+VIN	IN	Positive power input
23	NC	IN	Factory use only- do not connect
24	NC	IN	Factory use only- do not connect
25	NC	IN	Factory use only- do not connect
26	SYSFAULT	OUT	System fault (BIT Status)
27	PWR_GD	OUT	Power good (BIT status)
28	DTA_GD	OUT	Data good (BIT status)
29	GND	Power GND	Power GND
30	CHGND	IN	Chassis GNG
31	NC	IN	Factory use only- do not connect
32	NC	IN	Factory use only- do not connect
33	NC	NC	
34	NC	NC	

1.8 MMQ50-200-400 Prime interface (J1)

“NC” denotes “no connection”. No connection is to be made to these pins, even to an un-terminated wire in a cable bundle. They are for factory test and programming use only.

1.9 Specifications

The following tables show the specification for the MMQ50. See Appendix 3, Specification Definitions and Measurement Techniques for more details on how these parameters are measured.

Parameter	Criteria [Comment]
RATE CHANNELS	
Range	+/-200°/ sec
Turn-on to turn-on Stability (Repeatability at a fixed temp)	100°/hr, 1 σ
In-run Stability	50-200°/hr, 1 σ
Gyro bias	0.25°/sec, 1 σ
Noise floor (@ 15 minutes)	4-15°/hr, 1 σ
White Noise (angle random walk)	0.3 °/rt-hr (0.005 °sec/rt-Hz)
Scale Factor	0.01°/sec/count
Scale Factor error	5000 ppm (0.5%)
Alignment	5 mrad
Vibration Rectification	0.01 °/sec/g
g-sensitivity	50 deg/hr/g
Bandwidth (-3dB)	50 Hz, nominal
Bandwidth (-90°)	50Hz, nominal
Resolution	0.01°/sec
Full Scale Output	+/-32750 counts

ACCELERATION CHANNELS	
Range (See note 1)	+/-10g (max steady-state)
Turn-on to Turn-on Stability (Repeatability at a fixed temp)	2.5 mg, 1 σ
In-run Stability	3 mg, 1 σ
Accelerometer Bias	17.5 mg, 1 σ
Noise Floor (@15 minutes)	0.25 mg, 1 σ
White noise (velocity random walk)	0.5 mg/rt-Hz
Scale Factor	3200 counts/g
Scale Factor Error	5000 ppm (0.5%)
Alignment	5 mrad
Vibration Rectification	1.5 mg/g ²
Bandwidth (-3dB°)	50 Hz, nominal
Bandwidth (-90°)	50Hz, nominal
Resolution	1 mg
Full Scale Output	+/-32750 counts

GENERAL	
Input Voltage	+/-11.0 to +/-13.0 V DC, regulated.
Input Current	Steady state: +280mA, -80mA, nominal. Turn-on surge: Up to +/-400mA during first 500msec.
Serial Interface Data Rate	115.2k Baud rate
Output voltage (data)	RS-232
Output voltage (discrete signals)	LVTTL
Start-up Time	Less than 3.0 sec
Dimensions	See outline drawing
Weight	7 oz.

ENVIRONMENTAL	
Temperature, operating	-54°C to +70°C
Temperature, storage	-54°C to +85°C
Temperature rate-of-change	5°C/minute, maximum
Vibration, random (See note 1)	6.0 G RMS, 20Hz-2KHz, flat. Meets DO-160D curves C, C1.
Shock, operating (See note 1)	30g, 11ms. Meets DO-160D operational shock and crash safety.
Altitude	35,000ft. Meets DO-160D Category C.

Note 1: Output is limited to 10g to comply with Export Control regulations. Accelerometer data will be corrupted and the Over-range BIT set if average level exceeds 10g during an output frame. (Frame rate is 450Hz.) In addition, shock impulses and vibration inputs when combined with steady-state accelerations must not exceed 30g at any time, or the data will be corrupted. Please contact factory for more details.

1.10 Specification Definitions and Measurement Techniques

The following gives a brief description of how MMQ Acceptance tests are run, and provides definitions of the performance parameters specified. For informational purposes only, various other non-specified parameters are also defined, some with “typical” MMQ performance values.

1.10.1 Specifications vs. Acceptance Test Limits

As is common in the Inertial Measurement instrumentation arena, the design of the unit and the build process control are intended to ensure that the entire population of units meets the specification at a 1-sigma level, rather than the individual IMU.

The performance of individual MMQs are assumed to be on a normal distribution curve, with the 1-sigma point meeting the specification value, for each specified parameter. In order to allow a valid statistical analysis without an infinite population, the Acceptance Test limits are set at 2-sigma; units that exceed that value on any performance parameter are rejected. (This results in rejection of up to 6% of units that are in fact within the normal curve).

Statistical Process Control verifies that the performance of the entire population meets the published specification at the 1-sigma point on an on-going basis.

1.10.2 Measurement Techniques

The MMQ is calibrated by performing a number of spins and tumbles over its operating temperature range, gathering raw (uncompensated) data. Bias, scale factor and misalignment modeling coefficients are derived from this data, and stored within the unit. In all subsequent tests the compensation is performed within the unit, using these coefficients. To avoid any scale factor related errors, all bias parameters are measured in the absence of inertial inputs, i.e. no rate input, Zero-g (accels), no vibration. Unless otherwise stated, these are steady state values, measured after any transients due to power turn-on have subsided. Generally 15 minutes ensures good thermal equalization. Noise measurements similarly require the unit to be stabilized at a fixed temperature, with no inertial inputs. The tests are generally run in a factory-only “Test Mode” that is not available for Customer use. This mode commands the MMQ to output additional data such as internal temperatures and voltages which the factory uses to generate the calibration coefficients subsequently stored in the unit.

1.10.3 Definitions of Specifications

Specifications apply after sufficient time has been allowed after turn-on for the unit to thermally stabilize. Generally 15 minutes ensures adequate thermal equalization; performance is not specified until after this 15-minute warm-up period.

1.10.3.1 Turn-on to turn-on Stability (Specified)

Variation in bias from turn-on to turn-on. The standard deviation of the means of a number of turn-ons at the same temperature, with the turn-on transient removed. (40°C is used at ATP.) The mean of each turn-on is calculated, yielding a single number (equivalent to the bias) for that turn-on. Then the standard deviation of those means is calculated, and must meet the specified limit. This quantifies bias variations between turn-ons under the same environmental conditions, and is not a measure of noise or offset (i.e. absolute bias).

1.10.3.2 In-run stability (Specified)

The average of the standard deviations of a number of turn-ons over the specified range of operating temperatures. Typically, 30 minutes of data is gathered immediately after power is applied at -40°C, 25°C, +40°C, and 71°C, with the first few minutes of each turn-on transient discarded. The result for each sensor must meet the specified value. Because the standard deviation (and not the RMS) of each turn-on is calculated separately, and the results then averaged, this is a measure of bias stability, or noise, and not of bias offset.

1.10.3.3 Gyro and Accelerometer Bias (Specified)

The RMS of bias at any temperature, excluding any turn-on transients. A measure of the expected steady-state bias error when power is turned applied at any temperature. Typically, tested by a slow (0.3°/minute) full-temperature-range slew test. Temperature is slewed from ambient to hot, to cold, and back to ambient, so results include any temperature hysteresis

effects. The slew rate is slow enough to avoid temperature gradient effects. The compensation coefficients derived from a previous Calibration Test are used; power has been cycled between Calibration and Slew Test, so this includes turn-on to turn-on variation. The RMS of each sensor output over the duration of the test is calculated. Typically <500°/hr (gyros) and <7mg (accels).

1.10.3.4 Noise Floor (Specified)

Flicker floor of an Allen Variance plot of the bias, at a fixed temperature, after any turn-on transient has subsided. This corresponds to random, occasional changes in bias, with a lower frequency content than the white noise specification below. Characterizes changes over periods of minutes or seconds, but not long-term drift. Tested using 8 hours of data averaged into one-second intervals. The 15-minute point is considered to be the floor for the data, and must meet the specified value.

1.10.3.5 White Noise (Angle Random Walk) (Specified)

White noise. This is the most typical noise specification. Can be calculated from a PSD (the noise floor, ignoring any tones), or from the -1 slope on an Allen Variance plot. Performed at a fixed temp, after any turn-on transient has subsided. Data for this test is gathered at 450 frames/second, without averaging. The result for each sensor must meet the specified value.

1.10.3.6 RMS noise (Not Specified)

RMS of noise at a fixed temp, including non-white noise sources, such as tones.

1.10.3.7 Scale Factor Error (Specified)

Scale Factor is typically derived from a set of sensor output data taken versus rate inputs over the range of plus and minus full scale. The data set is reduced by deriving a Best Fit Straight Line (BFSL) of the output data using the Method of Least Squares. The slope of the BFSL is considered to be the Scale Factor.

Scale Factor Error is typically expressed in percent, and is calculated by dividing the Scale Factor derived from the BFSL (above) by the nominal Scale Factor, then multiplying by 100. The results for each sensor must meet the specified value. May alternately be expressed in ppm (parts per million).

Non-Linearity is defined as the maximum deviation of the measured data from the BFSL and is expressed as a percent of Full Range (F.R.). (Full Range = Full Scale multiplied by 2). A typical limit for Non-linearity < 0.05% F.R. An example calculation would be: $[(\text{Actual output} - \text{predicted output}) / (\text{Nominal Scale Factor} * \text{Full Range})] * 100 = \%F.R.$ (Not tested in production for the MMQ).

1.10.3.8 Alignment (Specified)

The misalignment of the sensing axes to the IMU mounting reference. A measure of the sensitivity of each axis to inputs in the non-sensitive axes, measured in terms of an angle (zero being perfect alignment). The angle is the RMS of a number measurements over temperature. Each angle (eg X into Y) must meet the specified requirement.

1.10.3.9 Orthogonality (Not Specified)

Measures the orthogonality of the sensors to each other. (Orthogonality and misalignment are software-corrected during calibration.)

1.10.3.10 Vibration Rectification (Specified)

The change in output during Vibration, due to Vibration. Changes due to other causes (such as temperature drift) are removed. Data is gathered before, during and after vibration. The mean value is calculated for each period. The before and after values are averaged, giving a nominal bias during the test. The difference between this and the value during Vibration is the Vibration Rectification. The test is performed in each of the three orthogonal axes, resulting in 9 values (3 axes X 3 sensors). These values for each sensor are then RMS'd together, and the result must not exceed the specified value.

NOTE: Due to the MMQ50's inherent sensing element design characteristics, there is notable vibration sensitivity at approximately 340 and 280 Hz. Subjecting the MMQ50 to extended periods of vibration at or near this frequency can negatively affect output.

1.10.3.11 Gyro g-sensitivity (Specified)

The change in gyro output due to acceleration. Specified, but not measured in production.

1.10.3.12 Cross-axis sensitivity (Not Specified)

The change in sensor output due to input in a non-sensitive axis.

1.10.3.13 Bandwidth (Specified)

Specified as the -3dB gain frequency and -90° phase shift frequency. May be defined a number of ways for a digital system, including separation into a sensor phase response and a fixed delay, or latency, resulting from processing/communication time. The MMQ50 bandwidth is nominally 50Hz, both Gain and Phase response, including all delays.

CONTACT INFORMATION

Systron Donner Inertial

2700 Systron Drive, Concord, California 94518

Customer Service: PH: +1 925.979.4500 • FAX: +1 925.349.1366

Sales and Technical Support: +1 866.234.4976

E-Mail: sales@systron.com • Website: www.systron.com