

QRS14

MEMS Quartz Angular Rate Sensor

Ideal for High-Precision Military Applications:

- Platform Stabilization
- Short Term Navigation
- GPS Augmentation
- Camera Stabilization
- Instrumentation
- Ride Control Stabilization
- Wind Turbine Control



Key Performance Features:

- **Solid State**
- **Compact, Lightweight Design**
- **Wide Temperature Range**
- **DC Input/High-Level DC Output**
- **Internal Power Regulation**
- **High Reliability**
- **Shock Resistant**



The QRS14 is a compact, rugged, solid-state inertial sensor used to measure angular rotation rates. It features a monolithic quartz sensing element, internal power regulation and DC input/high-level DC output operation. Two versions are available. The +12 Vdc version features a high-level +1.0 to +4.0 Vdc output, and operation from standard battery power. The plus and minus 15 Vdc version provides a high-level bipolar output of ± 5 Vdc, and is designed for use with conventional double-sided power supplies.

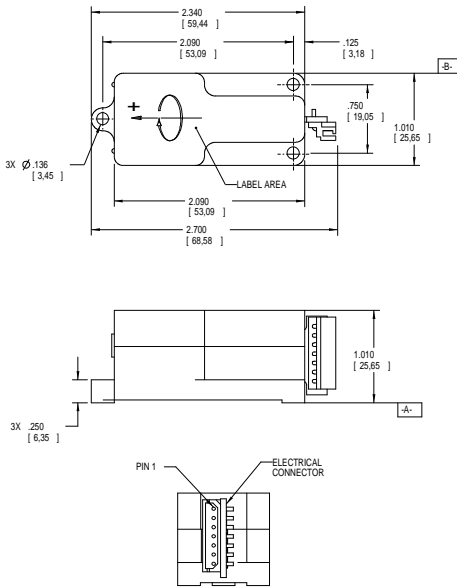

Notes:

1. QRS14 is supplied with a mating connector (Molex P/N 5264-7 or Equiv.).
2. Angular rate applied as shown will produce a positive output.
3. Unit of measure is in inches/[mm].
4. Built-in-test activated by grounding Pin 7 causes an increase in rate output (Pin 5) of 0.5 Vdc nominal.
5. Built-in-test activated by grounding Pin 7 causes an increase in rate output (Pin 5) of 1.0 Vdc nominal.

QRS14 -00XXX-102 PIN ASSIGNMENT

- | | |
|---|---------------------------|
| 1 | Power and Signal Ground |
| 2 | +Vdc Input |
| 3 | No connection, Leave Open |
| 4 | No connection, Leave Open |
| 5 | Rate Output |
| 6 | No Connection, Leave Open |
| 7 | Built-in-test (Note 4) |

QRS14 -00XXX-103 PIN ASSIGNMENT

- | | |
|---|---------------------------|
| 1 | -Vdc Input |
| 2 | +Vdc Input |
| 3 | Power Ground |
| 4 | Signal Ground |
| 5 | Rate Output |
| 6 | No Connection, Leave Open |
| 7 | Built-in-test (Note 5) |

	QRS14-0XXXX-102**	QRS14-0XXXX-103**
Power Requirements		
Input Voltage	+9 to +18 Vdc	+ and - 9 to 18 Vdc
Input Current	<20 mA	<25 mA (each supply)
Performance		
Standard Ranges	±50, 100, 200, 500°/sec.	
Full Scale Output (Nominal)	+1.0 Vdc (-FS) to +4.0 Vdc (+FS)	±5 Vdc
Scale Factor Calibration (at 22°C Typical)	±2% of value	
Scale Factor Over Temperature (Dev. from 22°C Typical)	≤0.06%/°C	
Bias Calibration (at 22°C Typical)	+2.5 ±0.045 Vdc	0.0 ±0.075 Vdc
Bias Variation over Temperature (Dev. from 22°C)	<3.0°/sec	
Short Term Bias Stability (100 sec at const. temp)	<0.05°/sec, typical	
Long Term Bias Stability (1 year)	≤1.0°/sec.	
G Sensitivity (Typical)	≤0.06°/sec/g	
Start-Up Time (Typical)	<2.0 sec	
Bandwidth (-90° Phase Shift)	>50 Hz	
Non-Linearity (Typical) % Full Range	≤0.05% of F.R.	
Threshold/Resolution	≤0.004°/sec.*	
Output Noise (DC to 100 Hz)	≤0.05°/sec./√Hz*	≤0.02°/sec./√Hz*
Environments		
Operating Temperature	-40°C to +85°C	
Storage Temperature	-55°C to +100°C	
Vibration Operating***	5 g _{rms} 20 Hz to 2 kHz random	
Vibration Survival***	10 g _{rms} 20 Hz to 2 kHz random 5 minutes/axis	
Shock	200g, any axis	
Weight	≤50 grams	

* Values indicated are for ±100°/sec. range

**"XXXX" designates ± range

*** Please see user's guide for more information regarding vibration tolerance and sensitivity.

For more information, contact:

Systron Donner Inertial
 2700 Systron Drive
 Concord, CA 94518 USA
 +1.866.234.4976 | sales@systron.com

www.systron.com