

QRS11

More than 250,000 QRS11's in the field!

Applications

The QRS11 has a wide variety of applications.

- Platform Stabilization and Pointing
- Guidance and Control
- Instrumentation
- Navigation
- Standby Attitude Indicator Systems

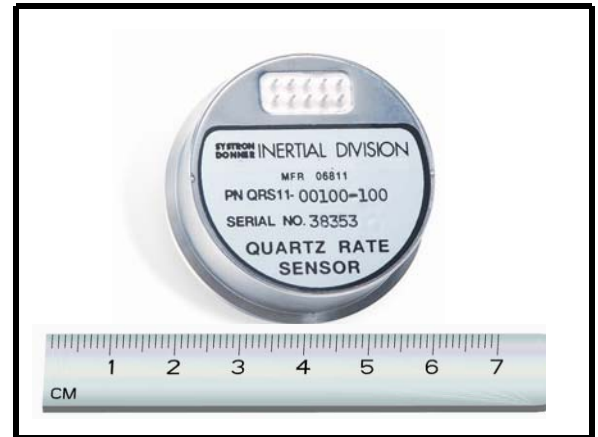

Description

The QRS11 is built with MEMS technology to deliver highly stable long-life performance in a small, lightweight package. With no moving parts, the quartz sensing element has virtually unlimited life while providing outstanding signal to noise performance. In production since 1991, the QRS11 provides reliable angular rate data in numerous aircraft, missile, space and commercial systems.



Key Performance Features

- Excellent Bias Stability
- Low Noise
- DC Input/High Level DC Output
- High MTBF
- Long Life
- Fast Start-Up

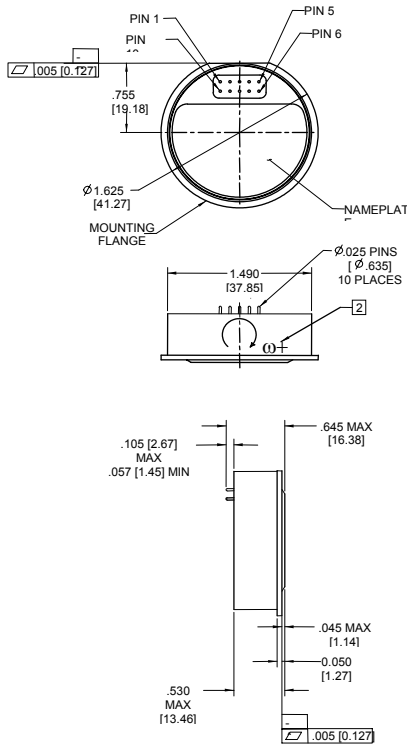

- Notes:
- QRS11 is supplied with two mounting rings, mounting screws & mating test connector.
 - Angular rate applied as shown will produce a more positive output (not marked on unit)
 - Unit of measure is inches [millimeters]
 - A DC voltage input of (± 1.0 Vdc Max) applied to the self-test will result in a proportional DC output voltage
 - TTL compatible BIT output signal of ≥ 2.4 Vdc (referenced to power ground) indicates a properly functioning unit.

QRS11 INPUTS / OUTPUTS
Self Test Input ⁴
+Vdc Input
Power Ground
BIT Output ⁵
Internal Temperature Sensor
Rate Output
Signal Ground
-Vdc Input
Case Ground

PARAMETER	SUMMARY SPECIFICATIONS	
Part Number	QRS11-00100-100	QRS11-00100-101
Performance Level	Standard	High
POWER REQUIREMENTS		
Input Voltage	+ and - 5 Vdc $\pm 3\%$ regulation	
Input Current	≤ 80 mA (each supply)	
Input Power Noise Limits	< 10 mV _{rms} wideband, except at 8.7 ± 0.5 kHz, < 1 mV _{rms}	
PERFORMANCE		
Standard Range Full Scale	$\pm 100^\circ/\text{sec.}$	
Full Scale Output (Nominal)	± 2.5 Vdc	
Scale Factor Calibration (at 22°C Typical)	$\leq 1\%$ of value	
Scale Factor over Temperature (Dev. from 22°C Typical)	$\leq 0.03\%/^\circ\text{C}$	
Bias Calibration (at 22°C Typical)	$\leq 2.0^\circ/\text{sec.}^*$	$\leq 0.5^\circ/\text{sec.}^*$
Bias Variation over Temperature (Dev. from 22°C)	$\leq 1.80^\circ/\text{sec.}^*$	$\leq 0.35^\circ/\text{sec.}^*$
Short Term Bias Stability (100 sec at const. temp)	$< 0.01^\circ/\text{sec.}$, typical*	
Long Term Bias Stability (1 year)	$\leq 0.2^\circ/\text{sec.}^*$	
G Sensitivity (Typical)	$\leq 0.02^\circ/\text{sec/g}$	
Start-Up Time (Typical)	< 1 sec.	
Bandwidth (-90°)	> 60 Hz	
Non-Linearity (Typical) % Full Range	$\leq 0.05\%$	
Threshold/Resolution	$\leq 0.004^\circ/\text{sec.}^*$	
Output Noise (DC to 100 Hz)	$\leq 0.01^\circ/\text{sec.}/\sqrt{\text{Hz}}^*$	
ENVIRONMENTS		
Operating Temperature	-40°C to $+80^\circ\text{C}$	
Storage Temperature	-55°C to $+100^\circ\text{C}$	
Vibration Operating	8 g _{rms} 20 Hz to 2 kHz Random (Consult factory for other vibration level requirements)	
Vibration Survival	20 g _{rms} 20 Hz to 2 kHz random 5 minutes/axis	
Shock	200g, any axis	
Weight	≤ 60 grams	
AVAILABLE OPTIONS		
<ul style="list-style-type: none"> Special Non-Standard Ranges $< \pm 100^\circ/\text{sec.}$ and $> \pm 100^\circ/\text{sec.}$, Consult Factory Extended Bandwidth Flying Leads Low Noise Extended Temperature Range 		

*Values indicated are for $\pm 100^\circ/\text{sec.}$ range

For more information contact:

Systron Donner Inertial
 2700 Systron Drive
 Concord, California 94518 USA
 +1-925-979-4500 or +1-866-234-4976



Email: Sales@systron.com