



QRS14 (GyroChip[®] II) User's Guide



MEMS Angular Rate Sensor *Model QRS14*

Sales and Customer Service
Systron Donner Inertial

Phone: (925) 979-4500
Fax: (925) 979-9827
E-Mail: sales@systron.com

Monday through Friday
7:00 am to 4:00 pm PST
Website: www.systron.com



LEASED DOCUMENT
DATE: 08-06-07



SAFETY AND HANDLING INFORMATION

- **DO NOT DROP!** The GyroChip II is a precision instrument. Excessive shock can adversely affect sensor performance.
- Avoid exposing the GyroChip II to electrostatic discharge (ESD). Observe proper grounding while handling.
- Insure that power leads are installed properly before applying power to the GyroChip II.

PATENT INFORMATION

The GyroChip II is protected by the following patents: U.S. 4,654,663; U.S. 4,524,619; U.S. 4,899,587; U.S. Re. 33,479, plus other U.S. and foreign patents pending.

Figure 1. Connector Wiring

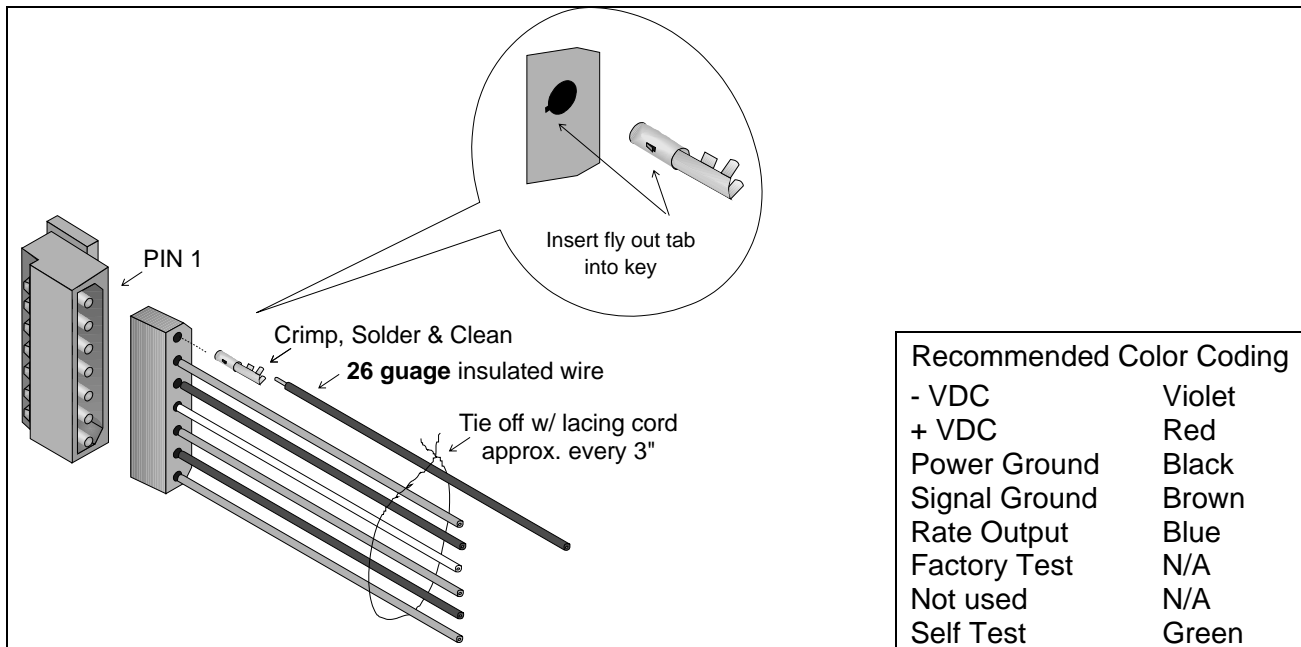

Table 1. Pin Assignments and Placement

Pin	Standard Model QRS14-00100-102	Low Noise Model QRS14-00100-103	Enter Color Used
1	Power/signal ground	- VDC	_____
2	+ VDC	+ VDC	_____
3	Not used	Power Ground	_____
4	Factory Test	Signal Ground	_____
5	Rate Output	Rate Output	_____
6	Factory Test	Factory Test	_____
7	Self-Test	Self-Test	_____

INSTALLATION

A. Connector Assembly

1. The Mating Connector (MOLEX 5264-7 or equivalent) packaged with the GyroChip II comes unassembled so that you can customize the wire lengths to your particular installation. You can use the recommended color-coding given in **Table 1**, or use your own coding system. *In either case, record the color codes you use in the spaces provided in **Table 1**.*
2. Cut 26 gauge insulated wire (stranded). Allow 2-4" beyond what you think you'll need to provide strain relief in your wire routing. Strip 1/4" insulation from the end of each wire. Pre-tin, clean and trim off the excess. Proper wire preparation is the key to a good solder bond; a clean soldering iron tip will help insure an uncontaminated solder joint.
3. Install each wire into the connector termination (see **Figure 1**) and crimp the wire into place with needlenose pliers. Make sure there is a good mechanical connection. Solder wires using a small-tipped 650-700° F iron for 3-5 seconds.
4. Check **Table 1** for proper pin assignment. Insert each pin into the proper hole, carefully aligning the flyout tab to the keyway (see detail in **Figure 1**). Be careful not to bend near the solder joint to avoid strand separation. Secure the wire bundle with lacing cable about every 3". Don't over-tighten the lacing. Insure that there is no stress on the wire terminations at either end.

Figure 2. GyroChip II Mounting Diagram

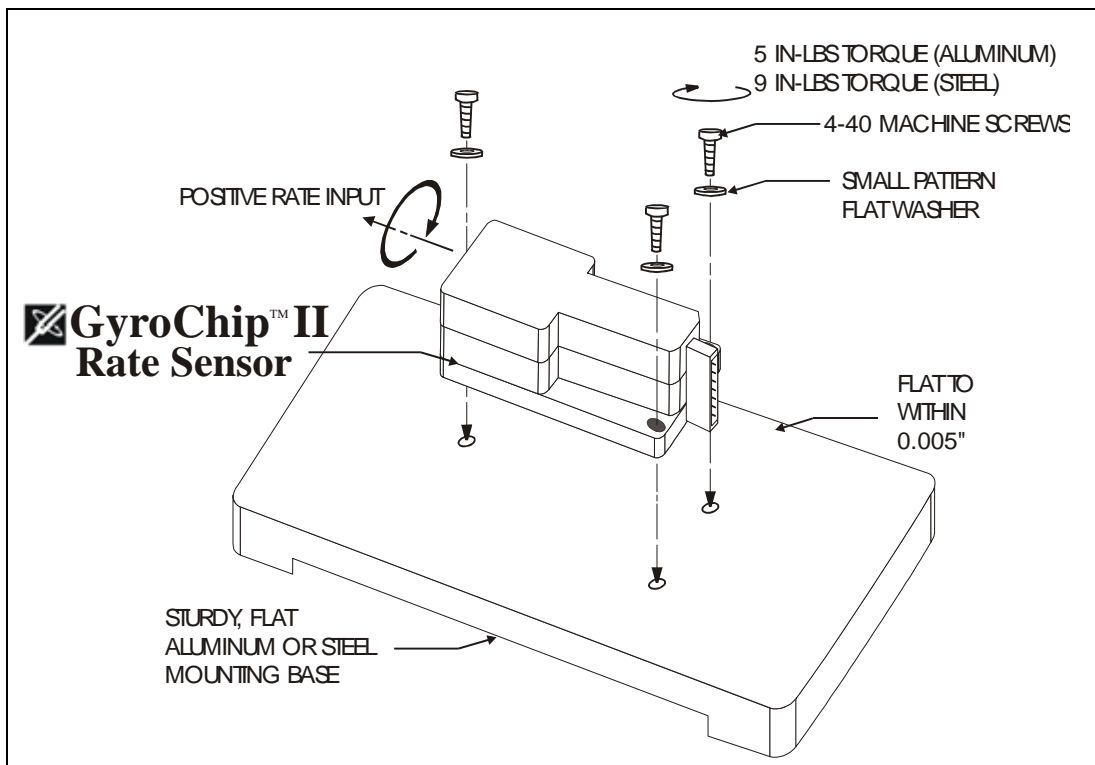

B. Mounting

1. Prepare the mounting surface. It should be sturdy and rigid, and must be flat within 0.005 inches. If the mounting surface flexes or vibrates, the GyroChip II will respond to the movement as an input.
2. Mount the GyroChip II using three small flat washers and 4-40 machine screws or equivalent. Refer to **Figure 2** for location of mounting holes. Be sure that washers lie flat with no interference from the side of the case. *Note that the sensitive axis orientation is parallel to the mounting surface.*
3. Tighten screws to 5 in-lbs of torque for mounting onto aluminum or 9 in-lbs for steel. Over-torquing may damage the case.

C. Connection

1. *Verify power supply polarity before connecting the GyroChip II. The instrument's internal electronics are NOT protected against reverse-polarity power.*
2. Connect the wires, referring to **Figure 1** and **Table 1**. Note the different pin designations associated with each model.
3. Connect the power ground to the common (ground) of the power supply. Signal ground is provided as a reference terminal for the rate output signal. There is an internal jumper between signal ground and power ground. (-103 model only) Case grounding provides a shield for the internal electronics and should make good contact with other chassis or shield grounds.
4. Minimize impedance of the supply power lines at the sensor. If you are using cables longer than three feet (3'), it is recommended to use solid tantalum bypass capacitors (10 μ f or more). Place the capacitors between the power lines and ground within 6" of the terminals on the rate sensor.
5. Shield power input lines if you are operating the GyroChip II in the presence of high levels of electromagnetic interference (EMI). Sources of EMI include switching power supplies and radio transmitters.
6. Insert a presampling filter when using an analog-to-digital (A-D) converter with the GyroChip II. Set the bandwidth of the presampling filter at 1/4 to 1/3 of the sampling frequency.

OPERATION AND TROUBLESHOOTING

When properly installed and connected, the GyroChip II should meet or exceed the specifications listed on page 7. If you do not achieve this level of performance when operating your GyroChip II, one of the following suggestions should resolve the problem. If not, please prepare a summary of your findings and call an Applications Engineer at Systron Donner Inertial: 866-BEI-GYRO (866-234-4976), Monday through Friday, 7:00-4:00 PST.

A. Self Test

Before conducting more detailed tests or troubleshooting, determine if the GyroChip II is performing its basic functions. You can conduct a basic self-test by shorting pin 7 to the power ground. Measure the Rate Output (pin 5), with input power applied and the GyroChip II stationary.

You should measure the following at the Rate Output, pin 5:

QRS14-0XXXX-102: 0.5 Vdc **QRS14-0XXXX-103:** 1.0 Vdc

B. Bias Not In Specification

1. *Structural Vibrations or Mounting Surface Movements.* The GyroChip II responds to very small angular rates. Observed voltage outputs, thought to be noise or bias, may result from real input motions caused by structural vibrations or mounting surface movements. Test the GyroChip II with all potential vibration sources shut off and compare performance with previous results. Alternatively, move the GyroChip II to a different mounting location or change the sensitive axis direction.
2. *Bias Shifts Caused by Ground Loops.* Ground loops may cause a bias shift that affects instrument performance. Check the wiring layout for ground loops.
3. *Crosstalk Between GyroChips.* Two or more GyroChips directly connected from the same power supply can possibly crosstalk, increasing bias or noise generation for each unit. First, eliminate power supplies as a cause of crosstalk (see #4 below). Then, test a single GyroChip II after disconnecting all others. If the noise or bias decreases, consider electrical isolation using an R-C Pi filter network on each of the lines to the individual GyroChips.
4. *Switching Power Supplies.* Some switching power supplies may cause a bias or noise increase in the output of the GyroChip II. Run one GyroChip II from a quality bench linear power supply, such as a Lambda Model LQD 422, or from a set of batteries, to see if the switching power supplies are the problem. If the bias/noise decreases, put a 100-uf capacitor and a 0.1µf ceramic bypass capacitor between the power supply lines and ground within 6" of the GyroChip II before reconnecting the switching power supplies.

Figure 3. Connection Diagram for Part Number QRS14-0XXXX-102

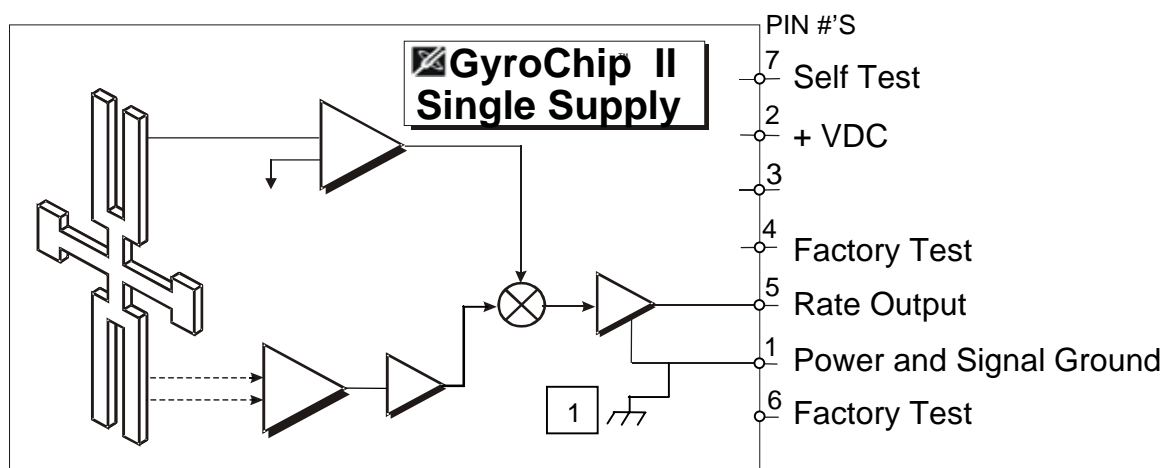

1 Power and signal ground tied to chassis internally.

Figure 4. Connection Diagram for Part Number QRS14-0XXXX-103

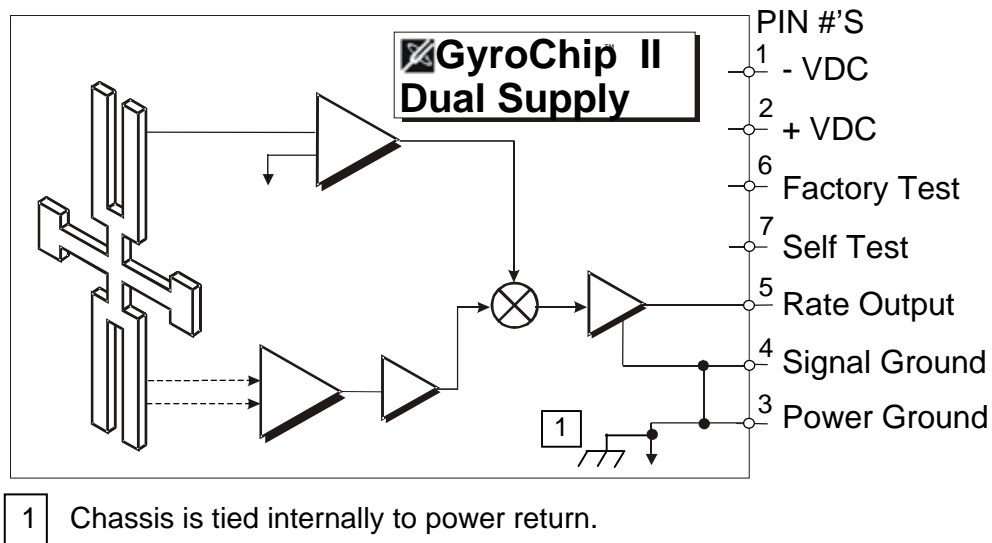

C. Output Tone at 340 Hz

Under certain conditions of shock and/or vibration, the GyroChip II can emit a narrow-bandwidth tone in the region of 340 Hz (± 20 Hz). This tone is usually not observable in output signals, because the sensor has an approximate corner frequency of 50 Hz with a signal rolloff of -12 dB per octave. If the tone becomes significant in your application, an appropriate filter may be used.

D. Technical Assistance

We want you to be thoroughly satisfied with our product. If you have questions or need assistance in operating your GyroChip II, please call us. You can reach an Applications Engineer at Systron Donner Inertial by calling 866-BEI-GYRO (866-234-4976).

Table 2. GyroChip® II (QRS14) Specifications

QRS14 Standard Part Numbers		
	Single Power Supply QRS14-00100-102	Dual Power Supply QRS14-00100-103

Power Requirements		
Input Supply Voltage	+9 to +18 VDC	+ and - 9 to + and - 18 VDC
Input Supply Current (max)	15 mA	20 mA (each supply)

Performance		
Range	$\pm 100^\circ/\text{sec}$	$\pm 100^\circ/\text{sec}$
Scale Factor ($\pm 2\%$)	15 mV/ $^\circ/\text{sec}$	50 mV/ $^\circ/\text{sec}$
S.F. Over Operating Temperature	< 4% from ambient	< 4% from ambient
Bias (initial offset)	+2.5 \pm 0.045VDC	+0.0 \pm 0.075VDC
Bias Stability		
Short-term (100 sec constant temperature)	< 0.05 $^\circ/\text{sec}$	< 0.05 $^\circ/\text{sec}$
Long-term (one year)	< 1.0 $^\circ/\text{sec}$	< 1.0 $^\circ/\text{sec}$
g Sensitivity (all axes)	< 0.06 $^\circ/\text{sec/g}$	< 0.06 $^\circ/\text{sec/g}$
Over Operating Environments	< $\pm 3.0^\circ/\text{sec}$, < $\pm 6.0^\circ/\text{sec}$ 1000 $^\circ$ Range	< $\pm 3.0^\circ/\text{sec}$ < $\pm 6.0^\circ/\text{sec}$ 1000 $^\circ$ Range
Linearity Error	< 0.05% of F.R	< 0.05% of F.R
Output Noise (to 100 Hz)	< .05 $^\circ/\text{sec}/\sqrt{\text{Hz}}$	< .02 $^\circ/\text{sec}/\sqrt{\text{Hz}}$ (50-200 $^\circ/\text{s}$) < .03 $^\circ/\text{sec}/\sqrt{\text{Hz}}$ (500-1000 $^\circ/\text{s}$)
Bandwidth (-90 $^\circ$ Phase shift)	> 50 Hz	> 50 Hz
Resolution and Threshold	< 0.004 $^\circ/\text{sec}$	< 0.004 $^\circ/\text{sec}$
Start-up time	< 2.0 sec	< 2.0 sec
Operating Life	10 years, typical	10 years, typical

Environments	
Operating Temperature	-40 $^\circ$ C to +85 $^\circ$ C
Storage Temperature	-55 $^\circ$ C to +100 $^\circ$ C
Vibration Operating	5 g _{rms} 20 to 2K Hz random
Vibration Survival	10 g _{rms} 20 to 2K Hz random, 5 min/axis
Shock	200 g pk, 2 ms, 1/2 sine

Figure 5. Outline Details for Model QRS14

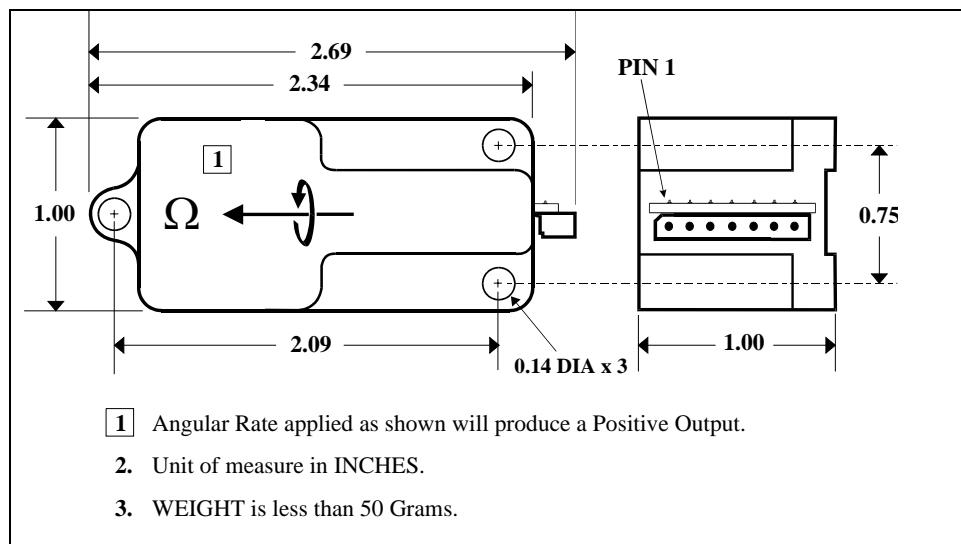

CONTACT INFORMATION

Systron Donner Inertial

355 Lennon Lane · Walnut Creek, California 94598

Customer Service: PH: 925-979-4500 · FAX: 925-979-9827

Sales and Technical Support: 866-BEI-GYRO (866-234-4976)

E-Mail: sales@systron.com · Web Site: www.systron.com

European Business Office: ++44 (0) 1227 776460 · FAX: ++44 (0) 1227 363289

E-Mail: bei.tech@ukonline.co.uk